

MANUAL SINGLE-PIPE VALVE

Art. 1455 - 1463 - 1473 - 1451 - 1452 - 1550 - 1575 - 1585 - 1595

1. ART. 1455 SINGLE-PIPE VALVE

This product combines the functions of both valve and lockshield valve. It is reversible, so pipes can be connected without pre-determining flow or return. It is more compact when compared to the Monostile valve and the position of the regulating control is parallel to the supply probe.

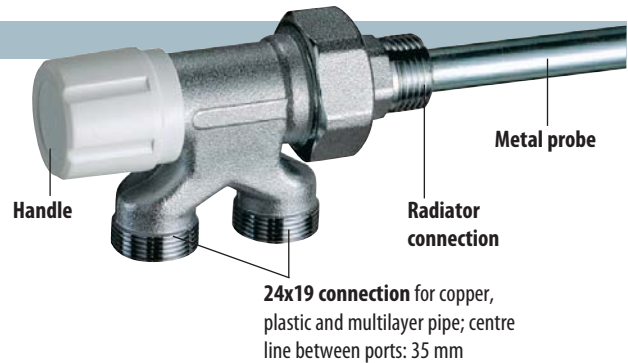

Central delivery flow

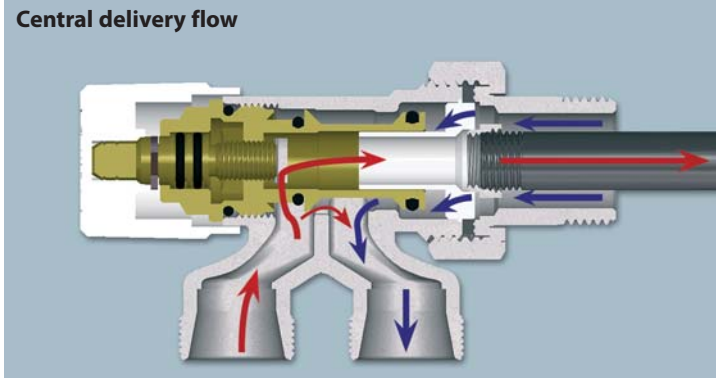

Example of wall installation



Lateral delivery flow

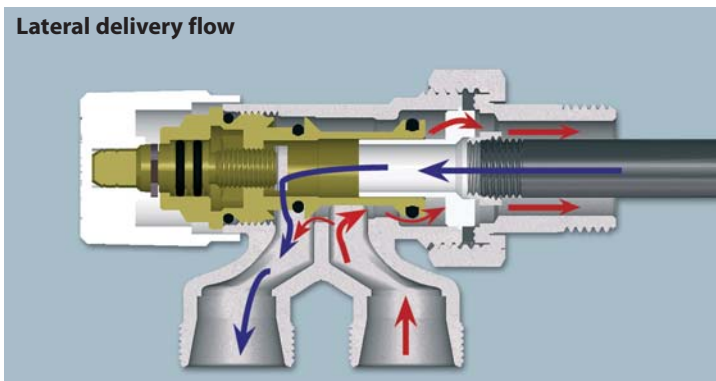

Example of floor installation

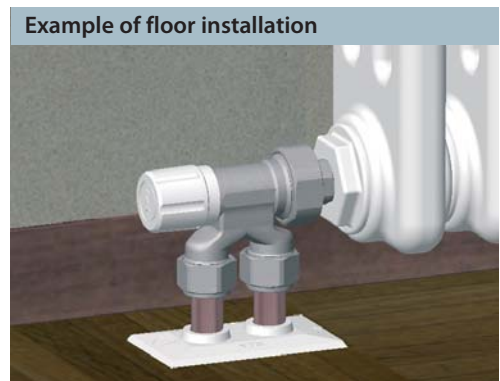

1.2 FAR INTERCHANGEABLE CONNECTIONS

Manual single-pipe valves have an interchangeable connection for copper pipe up to 16 mm, and for plastic and multilayer pipe up to 20 mm. A version is also available with a special connection for \varnothing 18 copper pipe.

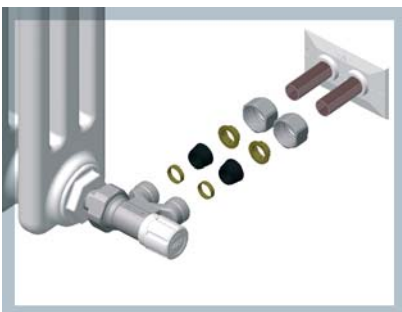

Example of installation with sealing kit for copper pipe. (The illustration shows the connection up to \varnothing 14 complete with a brass pipe guide washer - not needed for \varnothing 15 and \varnothing 16 mm)

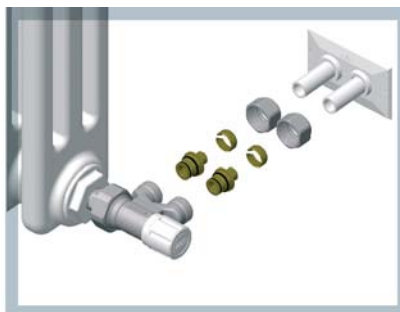

Example of installation of adapters for plastic pipe

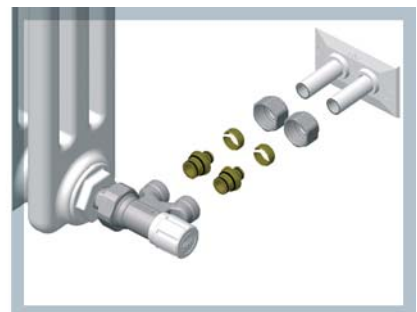

Example of installation of adapters for multilayer pipe

Sealing Kit

For the connection to copper, plastic and multilayer pipes FAR offers a wide range of sealing kits and adapters in different sizes to match the pipe dimensions.



Art. 6052

Kit for plastic pipes with 24x19 connection. Complete with:

- Adapter for plastic pipe
- Brass ring
- Chrome-plated nut with 24x19 thread



Art. 6055

Kit for multilayer pipes with 24x19 connection. Complete with:

- Adapter for plastic pipe
- Brass ring
- Chrome-plated nut with 24x19 thread



Art. 8427

Sealing compression kit in rubber for Ø10-12-14 copper pipe. Complete with:

- Brass pipe guide washer
- Rubber compression single-taper
- Brass ring
- Chrome-plated nut with 24x19 thread



Art. 8429

Sealing compression kit in rubber for Ø15-16 copper pipe. Complete with:

- Rubber compression single-taper
- Brass ring
- Chrome-plated nut with 24x19 thread

1.3 EXAMPLE OF INSTALLATION OF SINGLE-PIPE VALVES

Within a single-pipe circuit flow is by-passed in series from one radiator to another, with just a single flow and return to the manifold housing box. Illustration shows a circuit with 3 radiators with valves Art. 1455 and flow and return manifolds installed in the box.

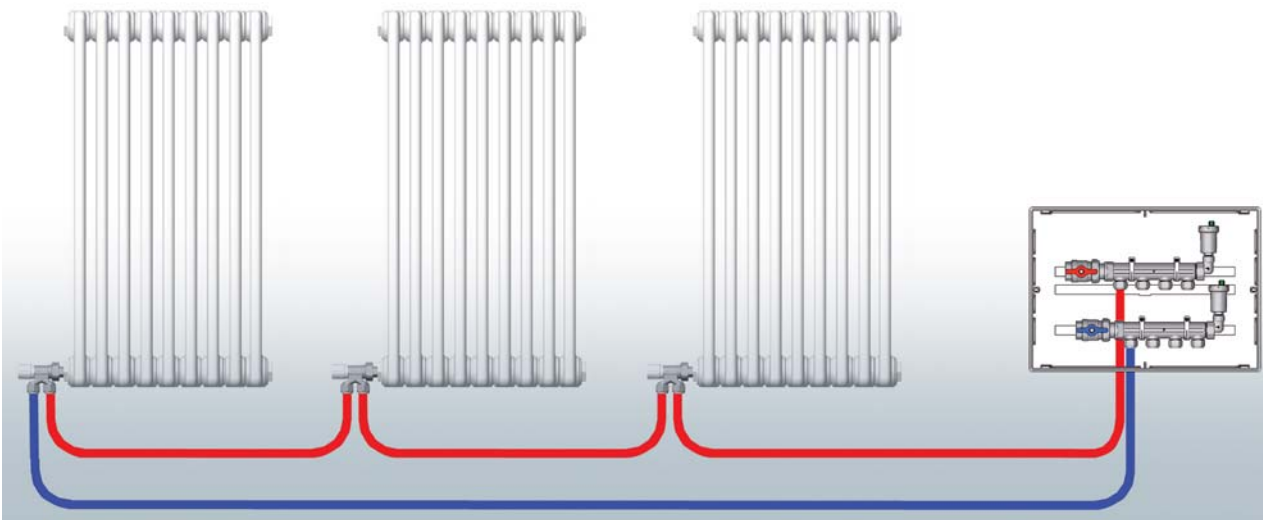

1.4 FLUID DYNAMIC, DIMENSIONAL AND TECHNICAL FEATURES

Fluid dynamic features

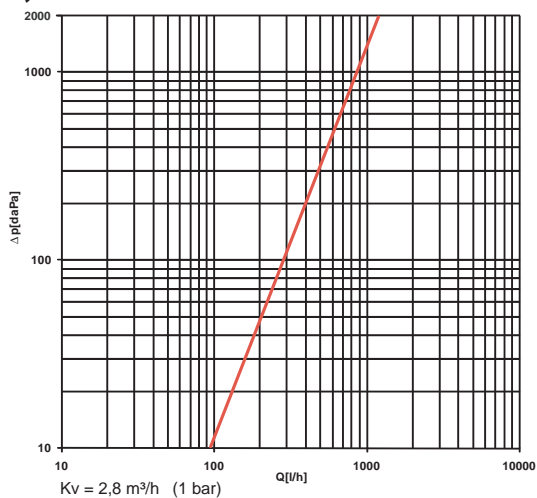

Dimensional features

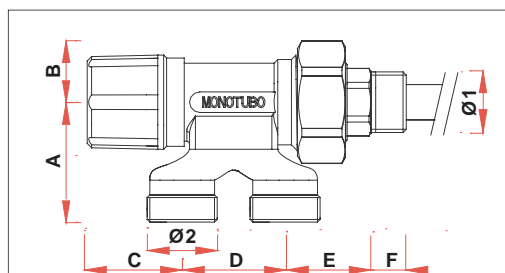

CODE	Ø1	Ø2	A	B	C	D	E	F
1455 1212	G1/2	24x19	41	21	33	35	31	11
1455 3412	G3/4	24x19	41	21	33	35	32	12

Technical features

Max. pressure:	10 bar
Max. working temperature:	95° C
Compatible fluids:	Water
Valve body:	CB753S brass
Handle:	ABS

Nut and union:	CW617N brass
Small parts:	CW614N brass
Probe:	Zinc-coated steel
Gaskets, O-rings:	EPDM

2. Art. 1463 - 1473 SINGLE-PIPE VALVES

These valves have the same features as Arts. 1450 and 1455. The only difference is the union with a connection for an external probe. Flow reversibility, as described above, is obtained by rotating the flow separator inside the union through 180°. The connection has a 24x19 thread and it permits to use copper pipes upto Ø 16, as externa probes.

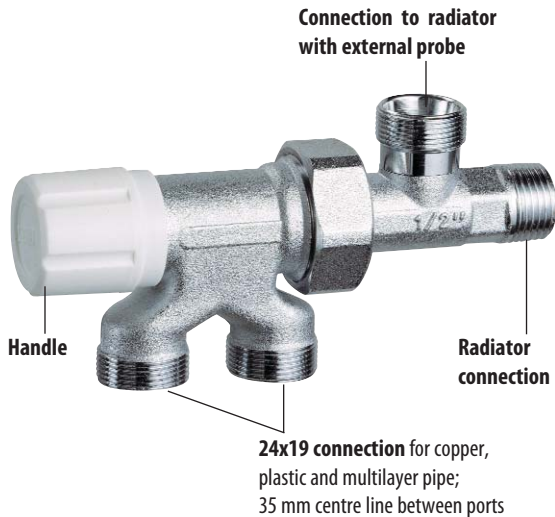

Central delivery flow - Fig. 1

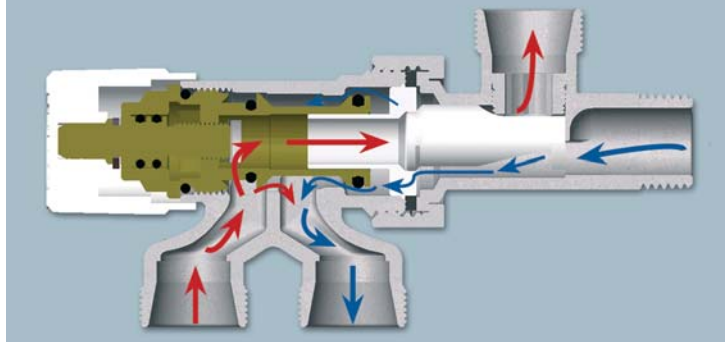

Lateral delivery flow - Fig. 2

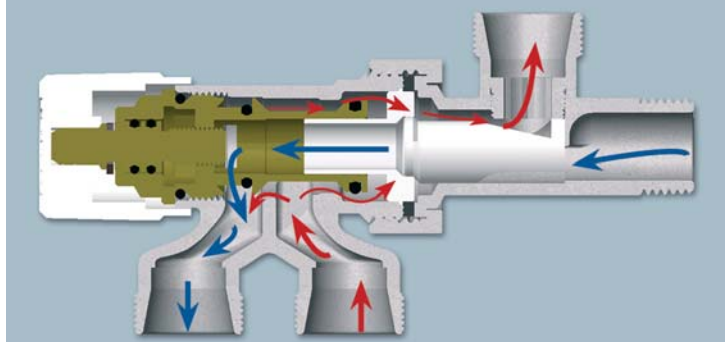

In side delivery configuration (Fig.2) the valve is provided with a flow separator. In order to obtained a central delivery configuration proceed as follows:

The connection with external probe permits fluid inlet into the upper part of radiator and fluid outlet into the lower section, thus guaranteeing optimal heat distribution.

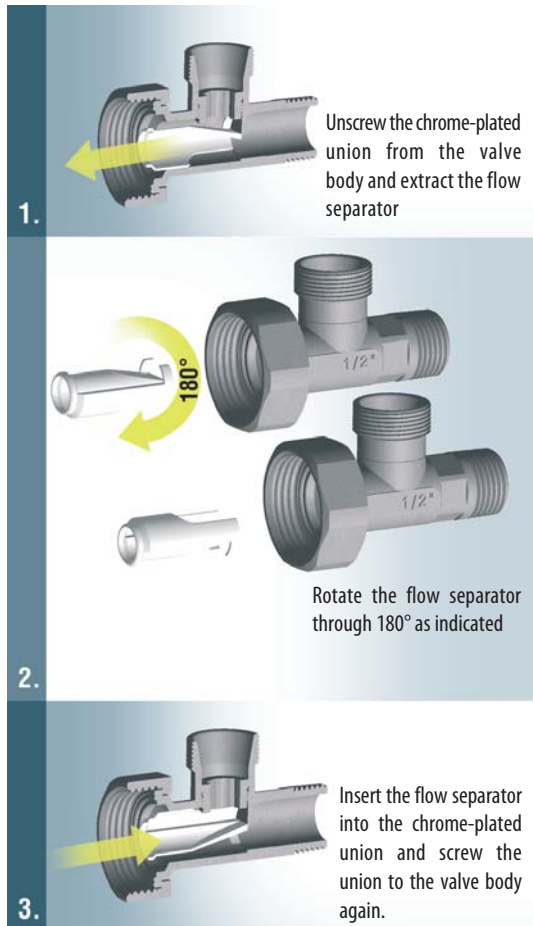

Example of wall installation of Art. 1473



Dimensional features

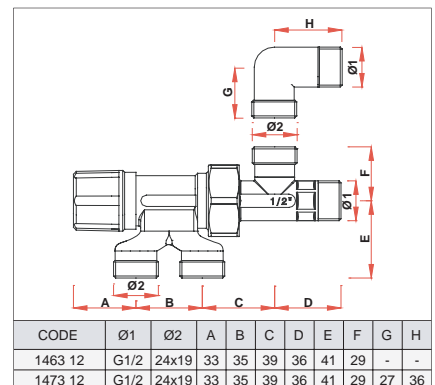

3. Arts. 1451 - 1452 "MONOFAR" SINGLE-PIPE VALVES

"Monofar" single-pipe valves feature the same valve body as Art. 1450, but have different connections to the radiator: Art. 1451 connects to the radiator by means of a probe; while Art.1452 is equipped with reversible unions for connection through the external probe.

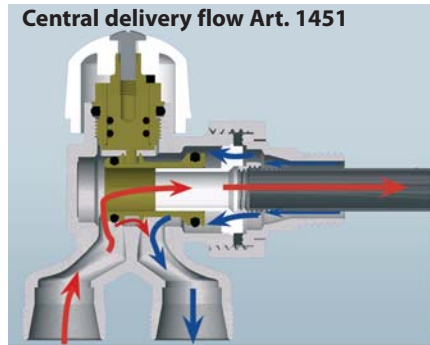
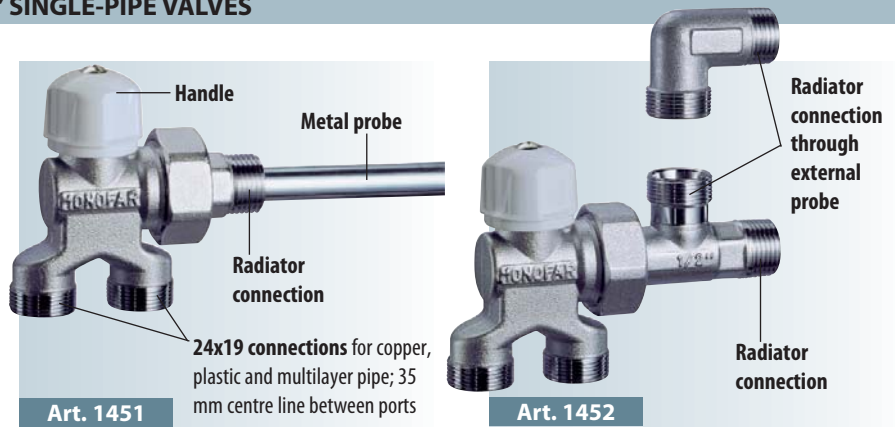

Central delivery flow Art. 1451

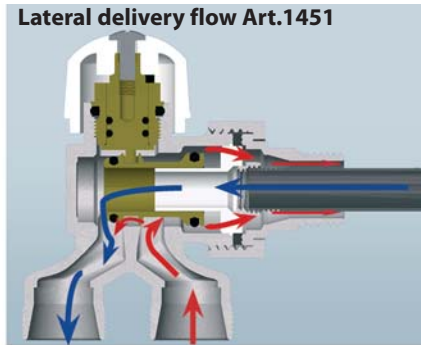

Lateral delivery flow Art.1451



Example of installation of Art.1451

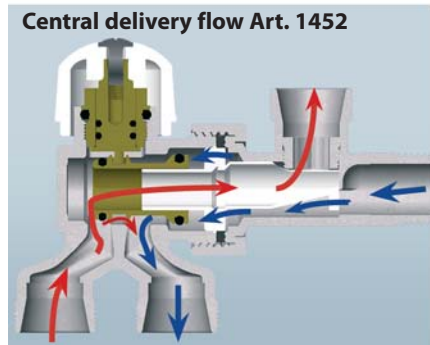

Central delivery flow Art. 1452

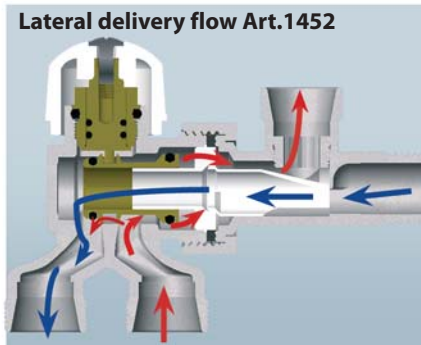

Lateral delivery flow Art.1452



Example of installation of Art.1452

3.1 FLUID DYNAMIC, DIMENSIONAL AND TECHNICAL FEATURES

Fluid dynamic features

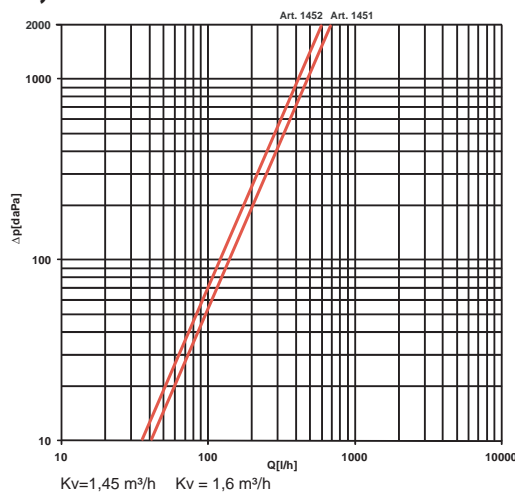

Dimensional features

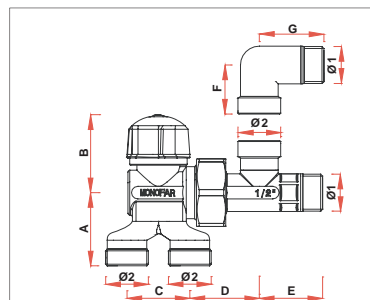

CODE	Ø1	Ø2	A	B	C	D	E	F	G
1452 12	G1/2	24x19	41	43	35	39	36	27	36

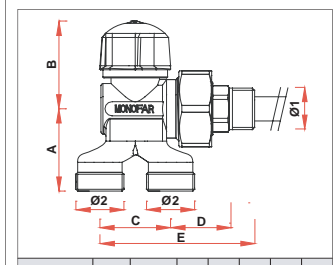

CODE	Ø1	Ø2	A	B	C	D	E
1451 1212	G1/2	24x19	41	43	35	31	77
1451 3412	G3/4	24x19	41	43	35	32	79

Technical features

Max. pressure:	10 bar
Max. working temperature:	95° C
Compatible fluids:	Water
Valve body:	CB753S brass

Handle:	ABS
Nut and union:	CW617N brass
Small parts:	CW614N brass
Gaskets, O-rings:	EPDM

4. Art. 1550 "MONODET" SINGLE-PIPE VALVE

The single-pipe valve, Art. 1550, has a control for opening and closing of water flow to the radiator and a lockshield valve for circuit balancing. It has one fixed by-pass and a second adjustable by lockshield valve opening.

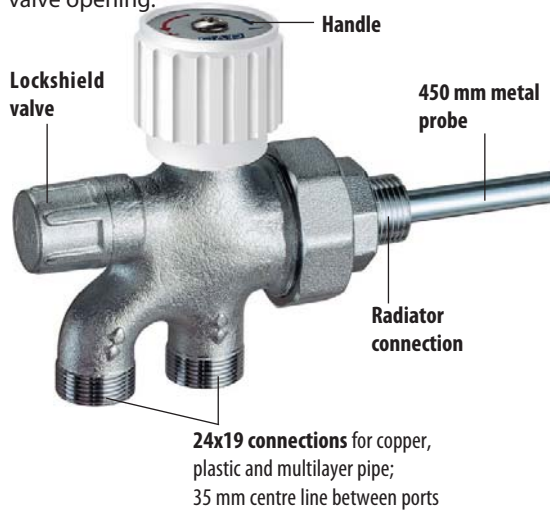

Central delivery flow

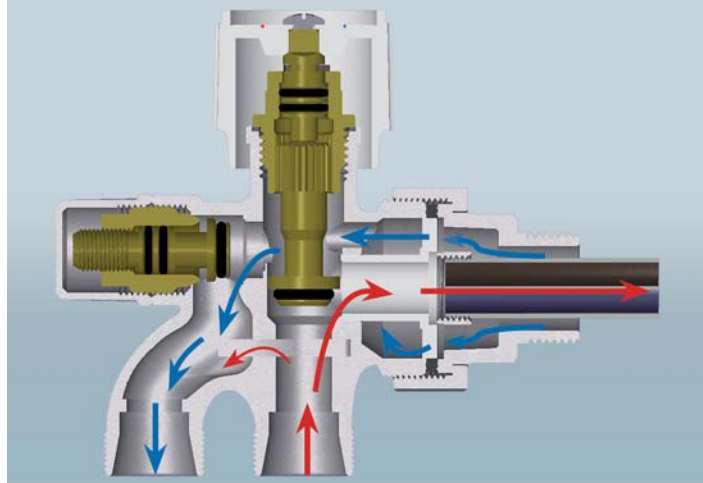

Lateral delivery flow

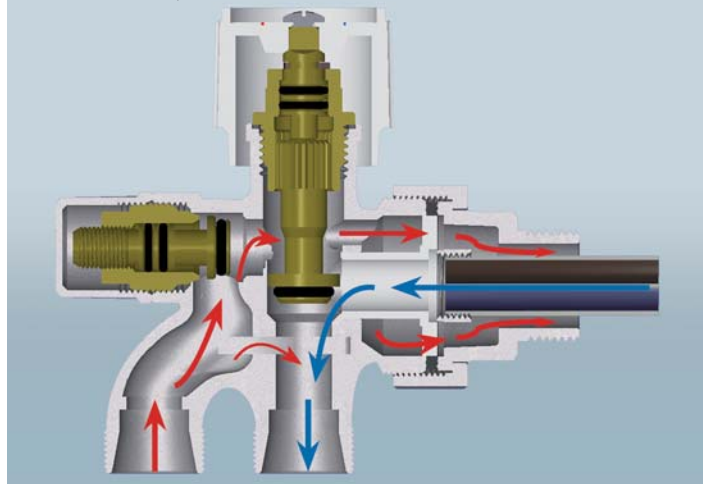

4.1 FLUID DYNAMIC, DIMENSIONAL AND TECHNICAL FEATURES

Fluid dynamic features

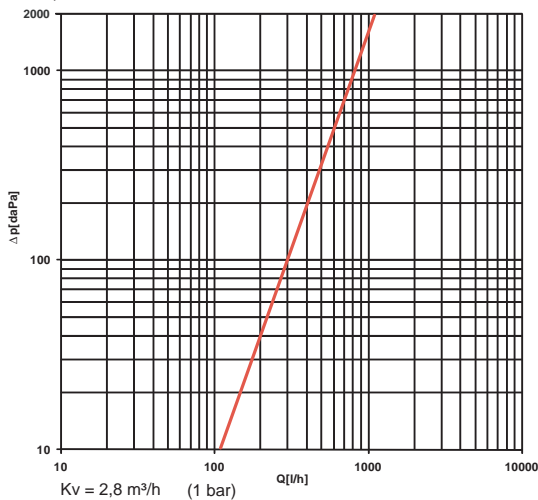

Dimensional features

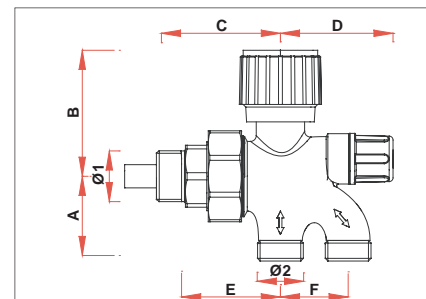

CODE	Ø1	Ø2	A	B	C	D	E	F
1550 1212	G1/2	24x19	44	65	63	59	51	35
1550 3412	G3/4	24x19	44	65	64	59	51	35
1550 3414	G3/4	24x19	44	65	64	59	51	35
1550 114D	G1DX	24x19	44	65	65	59	51	35
1550 114S	G1SX	24x19	44	65	65	59	51	35

Technical features

Max. pressure:	10 bar
Max. working temperature:	95° C
Compatible fluids:	Water
Valve body:	CB753S brass
Handle:	ABS

Nut and union:	CW617N brass
Small parts:	CW614N brass
Probe:	zinc-coated steel
Gaskets, O-rings:	EPDM

5. ART. 1575 SINGLE-PIPE VALVE

This product combines the functions of both valve and lockshield valve. Although it is a reversible valve, it is recommended that connection be made so as to feed the radiator directly from the external probe, as illustrated.

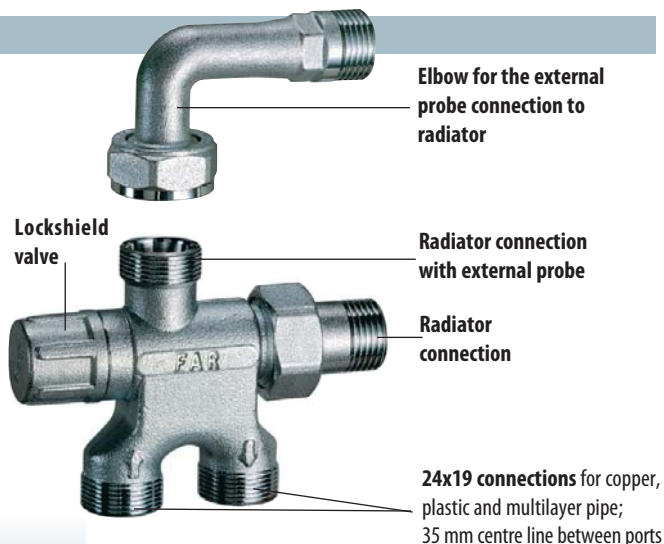

Flow circulation inside the valve

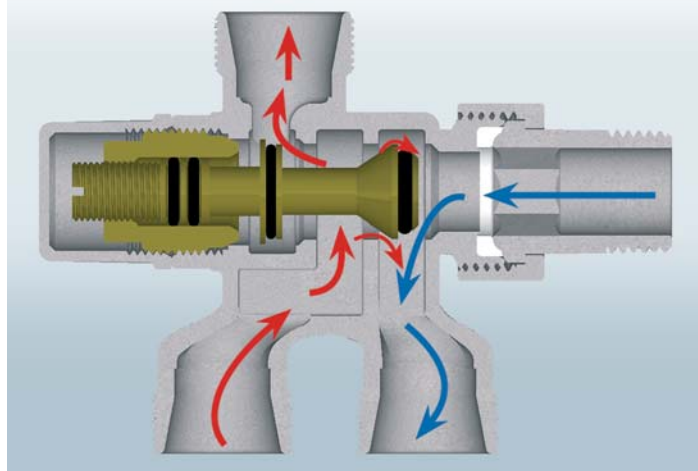

Example of floor installation



5.1 FLUID DYNAMIC, DIMENSIONAL AND TECHNICAL FEATURES

Fluid dynamic features

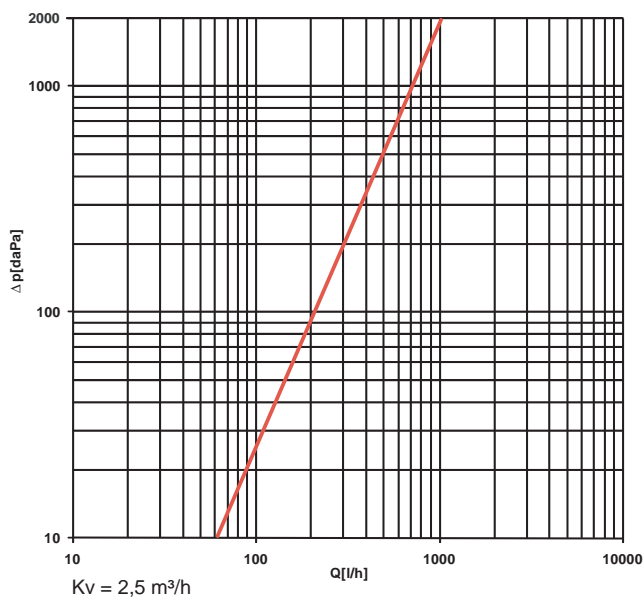

Dimensional features

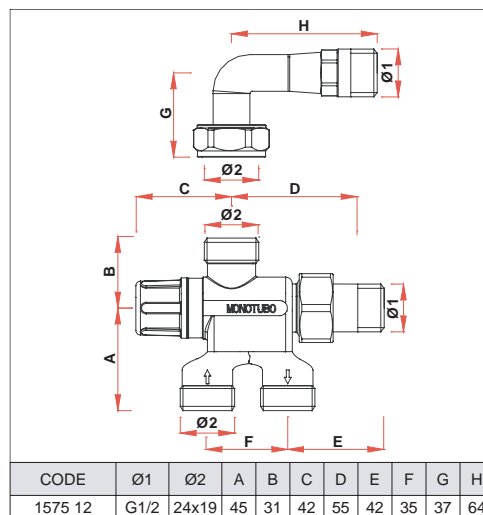

Technical features

Max. pressure:	10 bar
Max. working temperature:	95° C
Compatible fluids:	Water
Valve body:	CB753S brass

Handle:	ABS
Nut and union:	CW617N brass
Small parts:	CW614N brass
Gaskets, O-rings:	EPDM

6. Art. 1585 SINGLE-PIPE VALVE

This product combines the functions of both valve and lockshield valve. Unlike Art. 1575 this valve has a lockshield valve instead of a manual regulating valve. Although it is a reversible valve, it is recommended that connection be made so as to feed the radiator directly from the external probe, as illustrated.

Flow circulation inside the valve

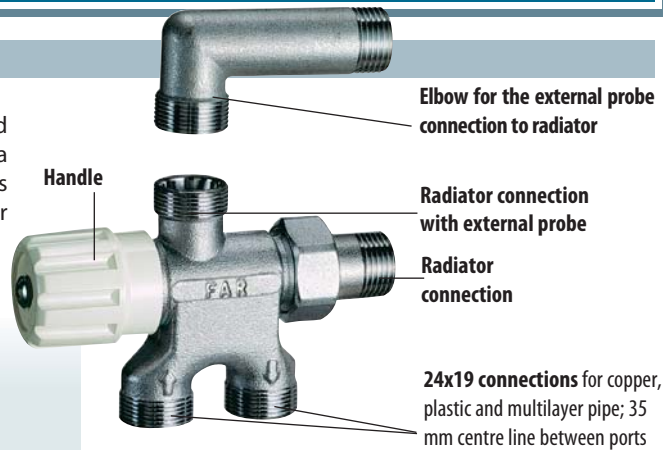
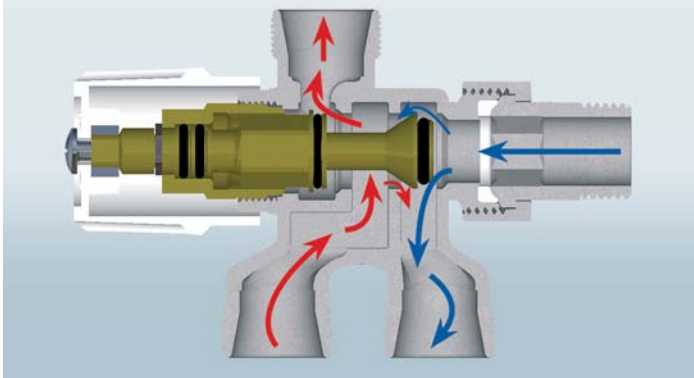

Example of floor installation



Beneath the regulating valve is a pre-regulation screw, the turning of which will reduce the flow passing through the radiator by limiting the shutter stroke. This feature is very important when the output of an existing radiator must be limited, or in the case of an oversized radiator. The pre-regulation screw is located in the same aperture as the regulating valve screw and can be reached with a screwdriver. Turns must be made clockwise. Increasing the number of turns causes the opening stroke of the valve and thus the flow to the radiator to decrease in proportion. To reduce the flow to the radiator and increase the by-pass flow, use the screwdriver clockwise after having totally closed the valve. The diagram shows the relationship between flow to the radiator and flow in the circuit.

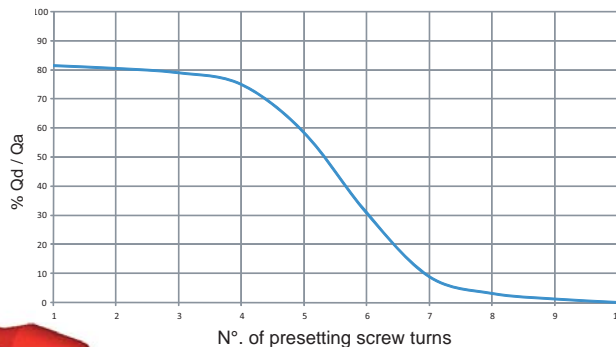

6.1 FLUID DYNAMIC, DIMENSIONAL AND TECHNICAL FEATURES

Fluid dynamic features

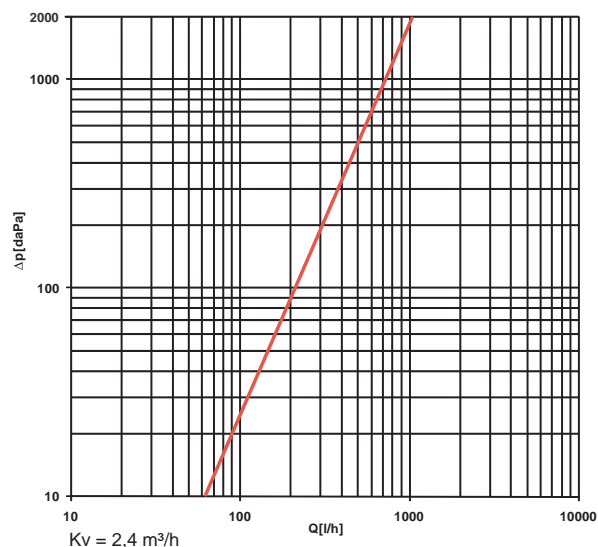

Dimensional features

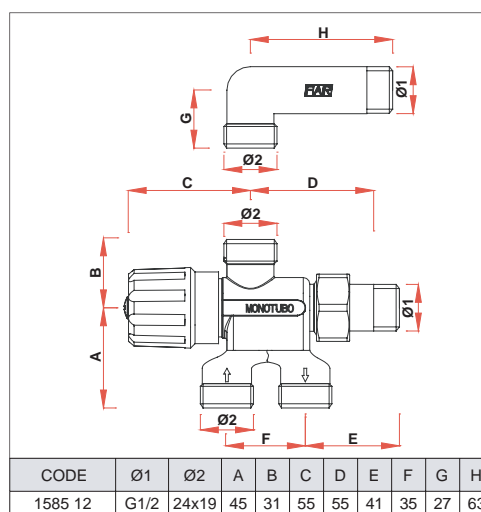

Technical features

Max. pressure:	10 bar
Max. working temperature:	95° C
Compatible fluids:	Water
Valve body:	CB753S brass

Handle:	ABS
Nut and union:	CW617N brass
Small parts:	CW614N brass
Gaskets, O-rings:	EPDM

7. Art. 1595 SINGLE-PIPE VALVE

This product combines the functions of both valve and lockshield valve. Although it is a reversible valve, it is recommended that connection be made so as to feed the radiator directly from the external probe, as illustrated.

Flow circulation inside the valve

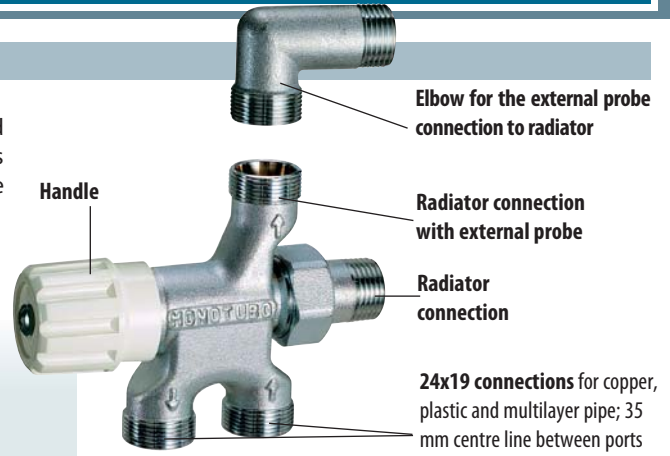
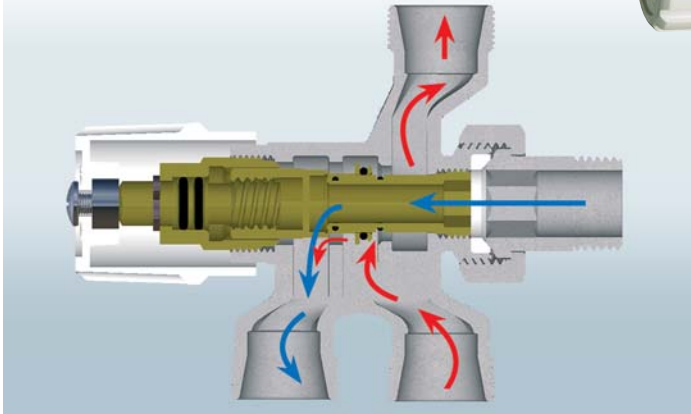

Example of floor installation



PRE-REGULATION SCREW

To decrease the flow to radiator and increase the by-pass flow, use the screwdriver clockwise, after having totally closed the valve. The diagram shows the relationship between flow to the radiator and flow in the circuit.

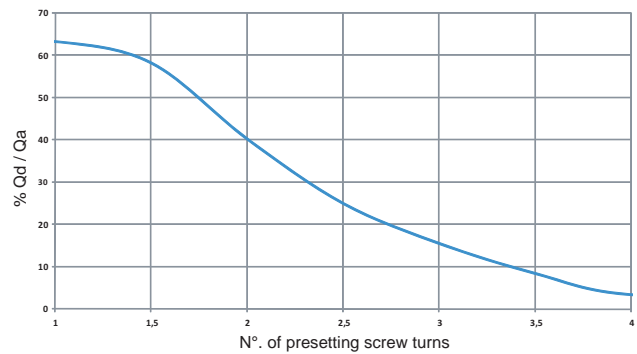

7.1 FLUID DYNAMIC, DIMENSIONAL AND TECHNICAL FEATURES

Fluid dynamic features

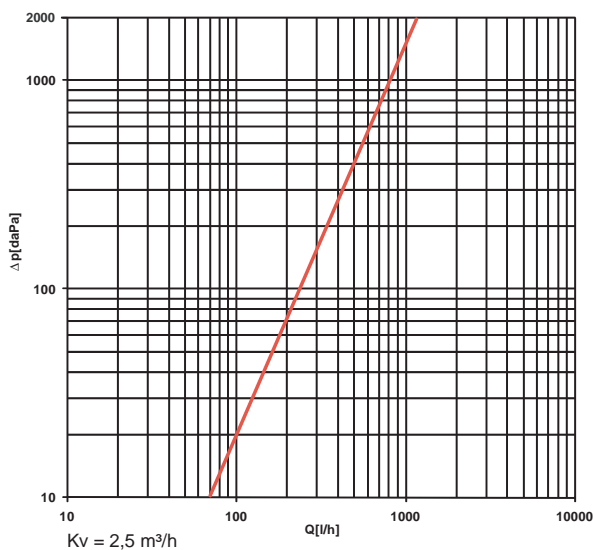

Dimensional features

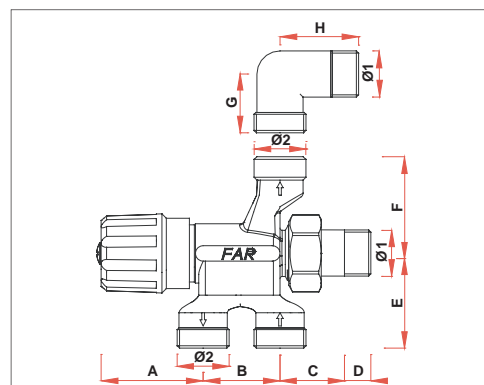

CODE	Ø1	Ø2	A	B	C	D	E	F	G	H
1595 12	G1/2	24x19	47	35	30	11	44	44	27	36

Technical features

Max. pressure:	10 bar
Max. working temperature:	95° C
Compatible fluids:	Water
Valve body:	CB753S brass

Handle:	ABS
Nut and union:	CW617N brass
Small parts:	CW614N brass
Gaskets, O-rings:	EPDM