

## MODULAR MANIFOLDS FOR HEATING AND COOLING SYSTEMS



Art. 3462



Art. 3465



Art. 3561\*

\* For the manifolds with flowmeters view the technical sheet ST.04.03.00.

### 1. DESCRIPTION

FAR offers a range of 1" and 1 1/4" modular manifolds suitable for installation in heating and cooling systems, to distribute flow to radiators or to floor, wall and ceiling, in case of underfloor heating systems; while FAR modular manifolds in 1 1/2" version are ideal for underfloor heating systems serving large surface areas (consult the technical sheet ST.04.02.00). FAR manifolds feature a special configuration which ensures easier flow transit, thus reducing flow resistance (Fig.1). Moreover thanks to a simple safety system, it is possible to replace the two O-ring seals on the body without any need to drain the system (Fig.2).

Manifolds are available pre-assembled, complete with supply

manifolds with built-in lockshield valves for system balancing and return manifolds with directional arrows, intermediate connection complete with automatic air vent valve, 0-80°C temperature gauge and drain cock. On the return manifolds it is possible to remove the blue handles and assemble the thermo-electric actuators, in order to control opening and closing of outlets by means of a thermostat or control unit.

The FAR inspections boxes offer a range of solutions for installation in purpose-designed housings.

All manifolds are available with FAR 24x19 copper pipe connections up to 16mm, up to 20mm for plastic and multilayer pipes and also with eurokonus connections.

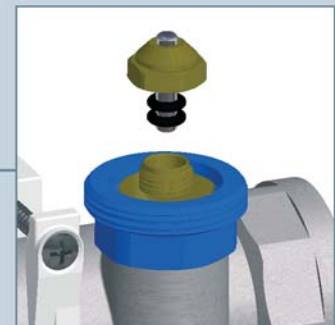
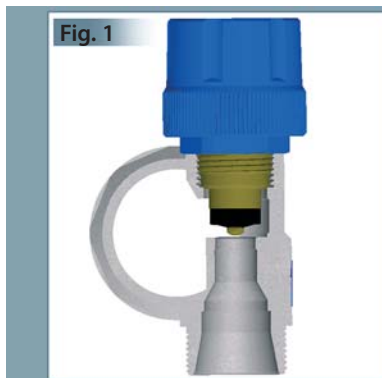

### 2. SYSTEM BALANCING

When system balancing, the position of the micrometric lockshield valve can be set with the aid of a 5 mm Allen wrench. To carry out calibration just remove the protective cap - no need for a wrench. In the following pages you will see flow resistance diagrams relating to manifolds with built-in lockshield valves - varying according to the number of lockshield valve turns.

It is possible to install flowmeters, or temperature gauges on manifolds connections to balance circuits.

FAR also offers manifolds with built-in flowmeters, which permit to directly read and control the quantity of fluid distributed to each terminal in l/min.

For further information about manifolds with flowmeters view the technical sheet ST.04.03.00.



### 3. CONSTRUCTION FEATURES

FAR modular manifolds are available with male-female and flanged connections. The flanged versions are available with 1" size and an o-ring seal between a manifold and another.



In order to identify connections place the grey disc with reference notation onto the handle - positioning it on the locking notch - then turn the second blue/red disc so that the window is positioned on the desired terminal.

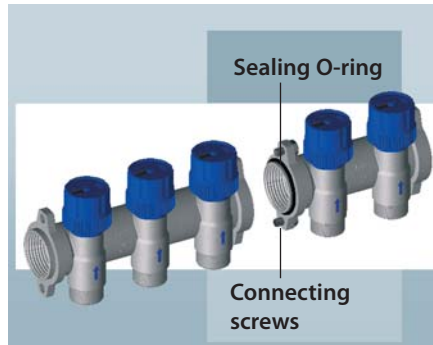

**In order to connect flanged manifolds proceed as follows:**

- Insert 34.59 x 2.62 O-ring as shown in the figure
- Insert screws in the special seats and tighten

### 4. INSTALLATION COMPONENTS

#### 4.1 THERMO-ELECTRIC ACTUATORS

Thermo-electric actuators are available in a 2-wired version, with phase and neutral wire, or in a 4-wired version, with connection to an auxiliary micro-switch. Opening /closing time is 180 seconds, with an option of 90 seconds, but only with a micro-switch. The actuators range comprises two types ie with working voltages of 24V or 230V. Both are available in Normally Closed (NC) or Normally Open (NO) versions. Without an

electrical supply, if the actuator is of the Normally Closed (NC) type, the valve, in case of manifolds the outlet, will remain shut; while, with an electrical supply an actuator of NC type will open the valve. Conversely, if the actuator is of the Normally Open (NO) type, without an electrical supply the valve will remain open.

**Thermo-electric actuator with 2 wires**



Code	Voltage	Type	Opening time
1909	24V	N.C.	180s
1919	230V	N.C.	180s
1929	24V	N.O.	180s
1939	230V	N.O.	180s

**Thermo-electric actuator with 4 wires and auxiliary micro-switch**



Code	Voltage	Type	Opening time
1913	24V	N.C.	90s
1914	24V	N.C.	180s
1923	230V	N.C.	90s
1924	230V	N.C.	180s

### INSTALLATION ON MANIFOLD

Fig.1

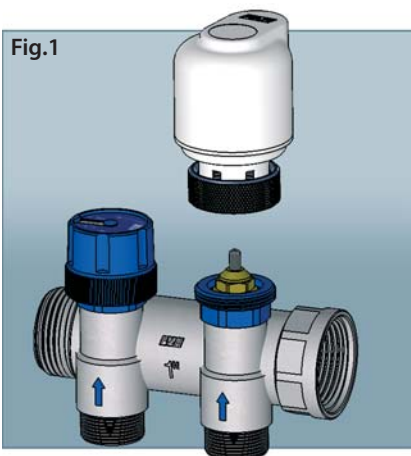

Fig.2

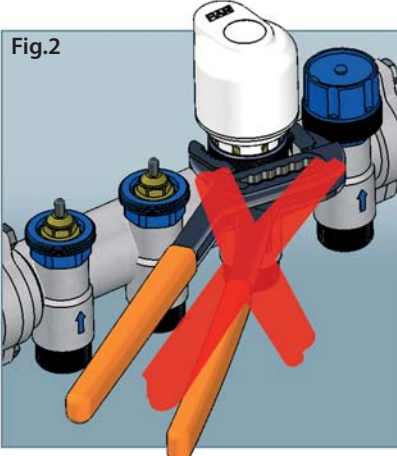
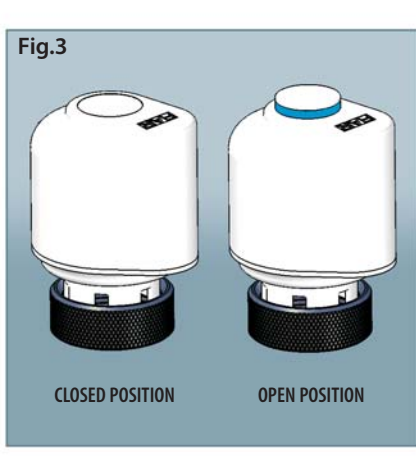

Fig.3



No adapter is required in order to install the actuator. Simply unscrew the blue handle from the manifold and then screw the actuator on the ring (Fig.1). The actuator must be lightly hand-tightened. Do not use any wrenches, which could

damage the actuator itself (Fig.2). Open and closed positions can be easily established with the aid of a blue strip located on the indicator (Fig.3). If any further details are needed, consult the Technical Sheet ST.04.05.00.

Thermo-electric actuators can open single circuits by means of a thermostat. Use of an auxiliary microswitch in the actuator makes it possible to shut down other equipment, such as circulating pumps, when valves close.

The illustration shows an example of installation for connection of some thermo-electric actuators equipped with auxiliary micro-switch.

Parallel connection makes it possible to set up the system such that once the last actuator closes, the pump or the boiler will also shut down. In this arrangement, once the first actuator opens it will permit the system to switch on, thus avoiding waste of electricity and reducing consumption.

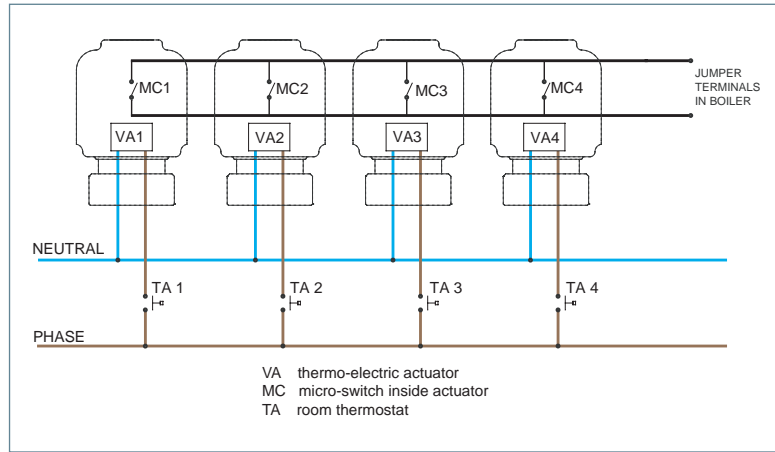

**4.2 TEMPERATURE GAUGE FITTING**



Balancing is generally designed around the dimension of the pipe used, but a more detailed calibration is required once system is complete by means of lockshield valves and temperature gauges installed on the return manifold from boiler. Regulating the flow via micrometric lockshield valves on the supply manifold, it is possible to increase or decrease the circulating flow rate and thus the return temperature of each circuit can also be regulated to the design value.

During installation it is essential to screw the nut on the corresponding outlet with the aid of a 27mm wrench. Sealing is guaranteed by an O-ring.

To the bottom of temperature gauge fitting can be connected copper pipes up to 16mm and plastic and multilayer pipes up to 20mm.

**Technical features**

Temperature range: 0-80°C
Max working pressure: 10 bar
Body material: CW617N
Temperature gauge housing: zinc-coated steel
Accuracy rating: 2,5

**Dimensional features**

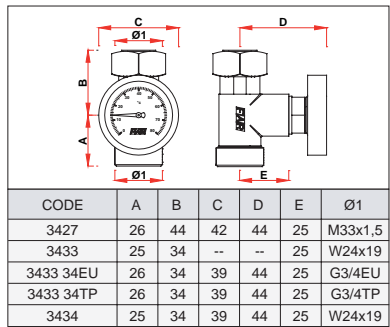

**4.3 FLOWMETER**



In modern heating system and particularly in panel radiator systems, circuit balancing is very important in achieving uniform flow distribution. The type of pipework to be used, radiator outputs, circulating flow, etc must all be calculated at the planning stage. Once the system is in operation, it will be necessary to adjust flow values as they will always differ - up or down for any given value - from those set in the design. This can be done by using manifolds with built-in micrometric lockshield valves to modify the quantity of water circulating in individual circuits by reading the flow on the outlet of the flowmeter. Flowmeters can be installed in any position bearing in mind the direction of the incoming flow indicated by the arrow on the body. They are available with scale from 1 to 3,5 l/min or from 2 to 8 l/min depending on system requirements.

Simple connection of the flowmeter to all FAR manifolds used in association with copper, plastic and multilayer pipes can be achieved by means of a swiveling nut.

The flowmeter can be connected to copper pipes up to 16mm and plastic and multilayer pipes up to 20mm.

**Technical features**

Working temperature: 95°C
Max working pressure: 10 bar
Scale: 1-3,5 2-8 l/min
Accuracy: ±10%
Body material: CW617N

**Dimensional features**

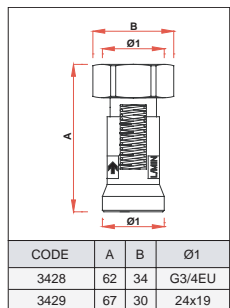

## 4.4 BY-PASS KIT

During operation one or more lines may be closed, i.e. in those areas in which there is no demand for heat transfer fluid. In this case there will be an increase in the resistance from these circuits and, therefore, the pump will work harder. In order to avoid this, a by-pass kit with built-in differential pressure valve is available for connection to the manifolds. Once a pre-set pressure level is reached this valve ensures discharge of excess flow on the return manifold allowing the pump to maintain a virtually constant speed.



Art. 3422

Overview of by-pass kit installation

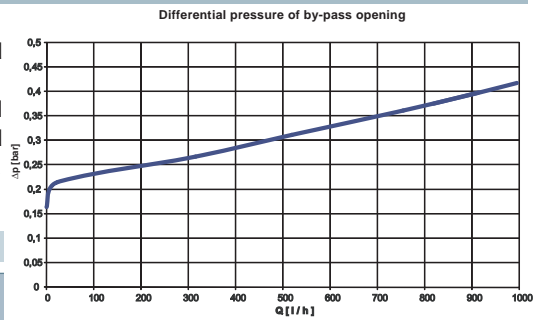
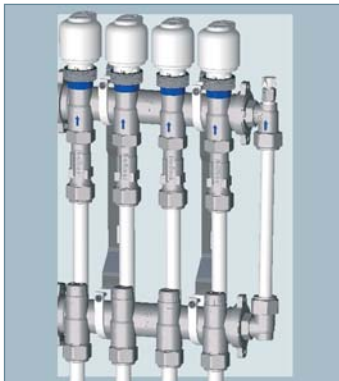

Typical differential pressure of by-pass kit

The above diagram shows pattern of flow passing from a differential by-pass valve, depending on upstream pressure. Opening is set at about 0,2 bar and, at this point, excess flow is sent back to the boiler.

## 4.5 INSULATION

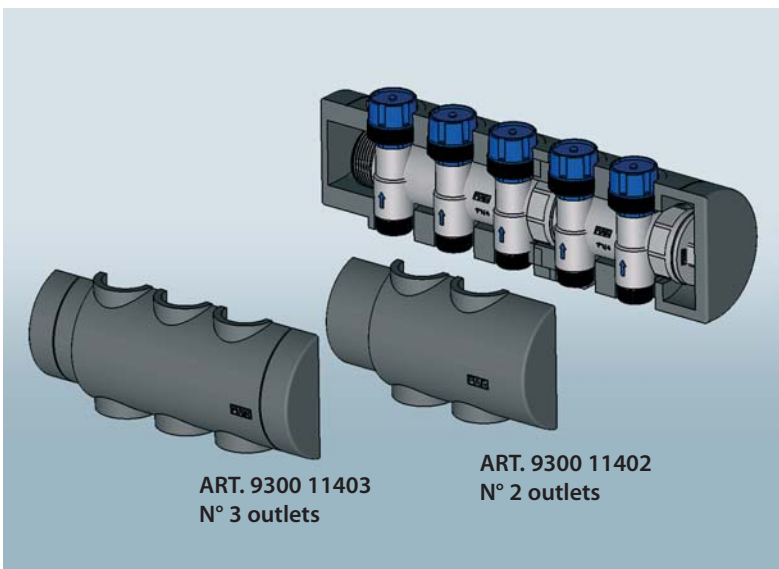

ART. 9300 11403  
N° 3 outlets

ART. 9300 11402  
N° 2 outlets

PPE pre-formed anti-condensation insulation can be used to thermally isolate manifolds. Insulation is available for modular 2, 3 and 4 port manifolds and must be assembled in the box after manifold installation.

Special insulation (Art.9301) has been designed for manifolds complete with air vent valves, drain cock and temperature gauge.

Closing plugs Art. 9302 suitable for use with this insulation are offered for supply manifolds, so that they will be fully isolated, once the lockshield valves have been regulated.

## 4.6 INSTALLATION IN PLASTIC INSPECTION BOX

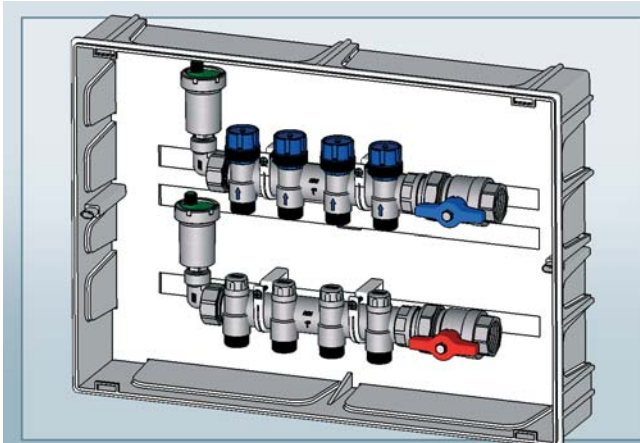

Modular manifolds can also be installed in "TUTTO" plastic inspection boxes. These plastic boxes are also designed to accommodate manifolds equipped with automatic air vent valves and are available in the following sizes:

Art.7410 50 , with sizes: 500x350x100

Art.7410 70 , with sizes: 700x410x100

Art.7410 90 , with sizes: 900x410x100

Location and fixing of manifolds is carried out by means of plastic supports suitable for a range of height locations. These permit optimum positioning of the pipework, allowing the manifolds to be placed in the most suitable position.

For further details consult the Technical Sheet for inspection boxes ST.06.02.00

**5. INSTALLATION IN METAL INSPECTION BOXES**

The tables below show the maximum recommended number of outlets to install. Dimensions have been calculated on the basis of an intermediate connection complete with air vent valve, temperature gauge and drain cock plus a terminal plug and ball zone valve.

**Art. 7148**



BOX WIDTH	COMPONENTS TO INSTALL
400 mm	4 port Manifold+Connection+Plug+Valve
500 mm	6 port Manifold+Connection+Plug+Valve
600 mm	7 port Manifold+Connection+Plug+Valve
800 mm	10 port Manifold+Connection+Plug+Valve
1000 mm	12 port Manifold+Connection+Plug+Valve
1200 mm	15 port Manifold+Connection+Plug+Valve

**Art. 7150**



BOX WIDTH	COMPONENTS TO INSTALL
400 mm	4 port Manifold+Connection+Plug+Valve
600 mm	7 port Manifold+Connection+Plug+Valve
800 mm	10 port Manifold+Connection+Plug+Valve
1000 mm	12 port Manifold+Connection+Plug+Valve
1200 mm	15 port Manifold+Connection+Plug+Valve

**Art. 7155**



BOX WIDTH	COMPONENTS TO INSTALL
400 mm	4 port Manifold+Connection+Plug+Valve
600 mm	7 port Manifold+Connection+Plug+Valve
800 mm	10 port Manifold+Connection+Plug+Valve
1000 mm	12 port Manifold+Connection+Plug+Valve
1200 mm	15 port Manifold+Connection+Plug+Valve

**Art. 7165**



BOX WIDTH	COMPONENTS TO INSTALL
700 mm	9 port Manifold+Connection+Plug+Valve
800 mm	10 port Manifold+Connection+Plug+Valve
900 mm	11 port Manifold+Connection+Plug+Valve
1000 mm	12 port Manifold+Connection+Plug+Valve
1100 mm	13 port Manifold+Connection+Plug+Valve
1200 mm	15 port Manifold+Connection+Plug+Valve

For further details consult the Technical Sheet of inspection boxes ST.06.01.00

**6. CONSTRUCTION MATERIALS AND TECHNICAL FEATURES**

**Construction materials**

Manifold body: CB753S brass
Body: CW614N brass
O-ring: EPDM
Handle and ring: ABS

**Technical features**

Nominal pressure: 10 bar
Working temperature range: 5÷95°C
Compatible media: water, water with glycol

**NB:** The above features are valid for both manifolds with valves and manifolds with lockshield valves

**7. CONNECTIONS TYPES AND RELATED ITEMS**

**FAR CONNECTION**



- Connections to the manifold can be made with:
- Multilayer pipe up to Ø20 mm
  - Plastic pipe up to Ø20 mm
  - Ø 10-12-14 mm copper pipe
  - Ø 15-16 mm copper pipe

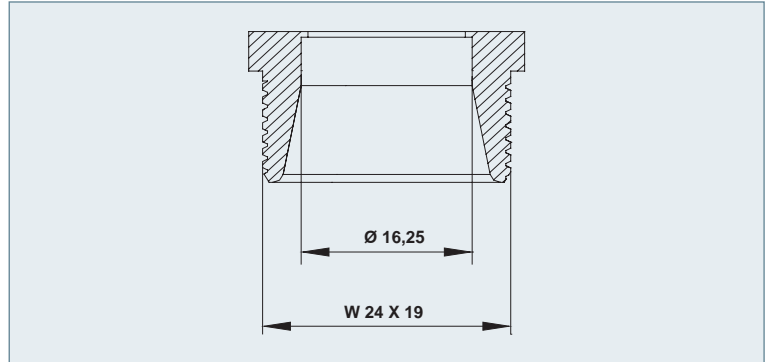

**EUROKONUS CONNECTION**

It is available in 1/2" and 3/4" sizes.  
It makes it possible to connect multilayer and plastic pipes to the manifold by means of the adapters Art.6076 and 6075.

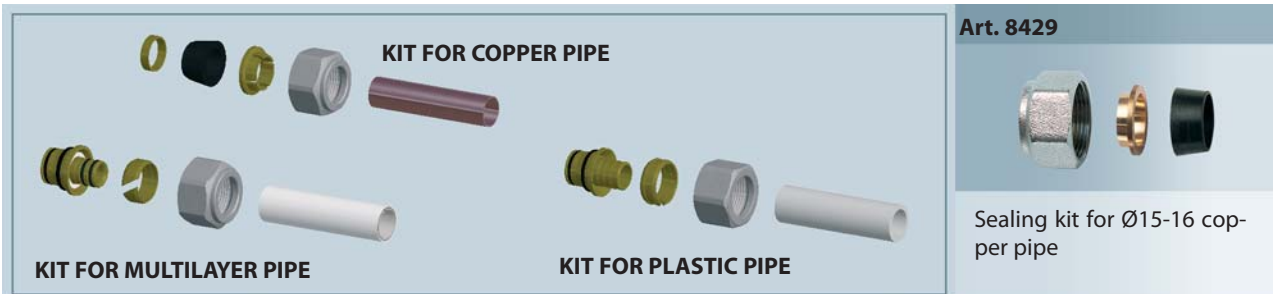
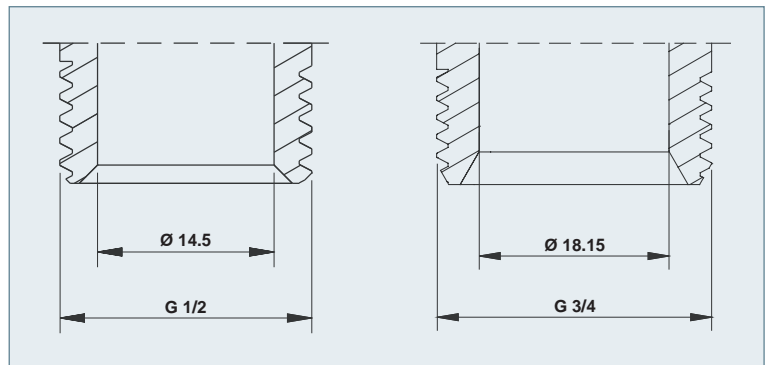

<p><b>Art. 8427</b></p>	<p><b>Art. 6052</b></p>	<p><b>Art. 6055</b></p>	<p><b>Art. 6075</b></p>
<p>Sealing kit for Ø10-12-14 copper pipe</p>	<p>Kit for plastic pipe with interchangeable sizes</p>	<p>Kit for multilayer pipe with interchangeable sizes</p>	<p>Kit for plastic pipe with EUROKONUS connection</p>
<p><b>Art. 6076</b></p>	<p><b>Art. 8850</b></p>	<p><b>Art. 8865</b></p>	<p><b>Art. 8870</b></p>
<p>Kit for multilayer pipe with EUROKONUS connection</p>	<p>Chrome-plated straight extension with FAR W24x19 connection</p>	<p>Reducer which permits changing a FAR W24x19 connection in a 1/2"-3/4" male thread</p>	<p>Reducer which permits changing a FAR W24x19 connection in a 1/2" female thread</p>

## 8. FLUID DYNAMIC FEATURES

### FLOW RESISTANCE OF RETURN MANIFOLD WITH BUILT-IN VALVES

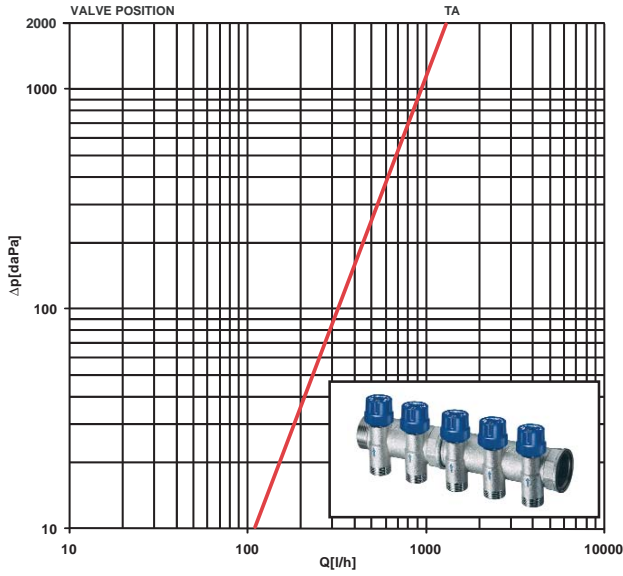

$K_v = 2,74 [m^3/h]$

### FLOW RESISTANCE OF RETURN MANIFOLD WITH BUILT-IN LOCKSHIELD VALVES

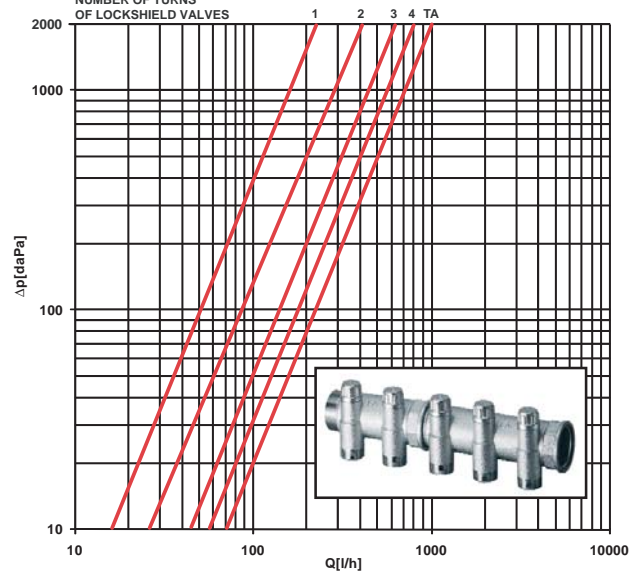

TURNS	1	2	3	4	TA
$k_v[m^3/h]$	0.5	0.92	1.36	1.81	2.16

## 9. DIMENSIONAL FEATURES

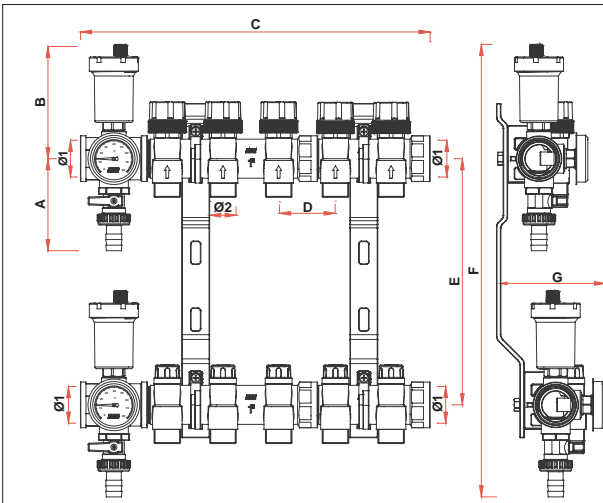

CODE	OUT.	Ø1	A	B	C	D	E	F	G	Ø2
3462-3468	2	G1	82	103	165	50	210-230	395-415	96	24x19-G1/2-G3/4
3462-3468	3	G1	82	103	215	50	210-230	395-415	96	24x19-G1/2-G3/4
3462-3468	4	G1	82	103	265	50	210-230	395-415	96	24x19-G1/2-G3/4
3462-3468	5	G1	82	103	315	50	210-230	395-415	96	24x19-G1/2-G3/4
3462-3468	6	G1	82	103	365	50	210-230	395-415	96	24x19-G1/2-G3/4
3462-3468	7	G1	82	103	415	50	210-230	395-415	96	24x19-G1/2-G3/4
3462-3468	8	G1	82	103	465	50	210-230	395-415	96	24x19-G1/2-G3/4
3462-3468	9	G1	82	103	515	50	210-230	395-415	96	24x19-G1/2-G3/4
3462-3468	10	G1	82	103	565	50	210-230	395-415	96	24x19-G1/2-G3/4
3462-3468	11	G1	82	103	615	50	210-230	395-415	96	24x19-G1/2-G3/4
3462-3468	12	G1	82	103	665	50	210-230	395-415	96	24x19-G1/2-G3/4
3462-3468	2	G11/4	89	107	165	50	210-230	406-426	107	24x19-G3/4
3462-3468	3	G11/4	89	107	215	50	210-230	406-426	107	24x19-G3/4
3462-3468	4	G11/4	89	107	265	50	210-230	406-426	107	24x19-G3/4
3462-3468	5	G11/4	89	107	317	50	210-230	406-426	107	24x19-G3/4
3462-3468	6	G11/4	89	107	367	50	210-230	406-426	107	24x19-G3/4
3462-3468	7	G11/4	89	107	418	50	210-230	406-426	107	24x19-G3/4
3462-3468	8	G11/4	89	107	468	50	210-230	406-426	107	24x19-G3/4
3462-3468	9	G11/4	89	107	518	50	210-230	406-426	107	24x19-G3/4
3462-3468	10	G11/4	89	107	568	50	210-230	406-426	107	24x19-G3/4
3462-3468	11	G11/4	89	107	618	50	210-230	406-426	107	24x19-G3/4
3462-3468	12	G11/4	89	107	668	50	210-230	406-426	107	24x19-G3/4

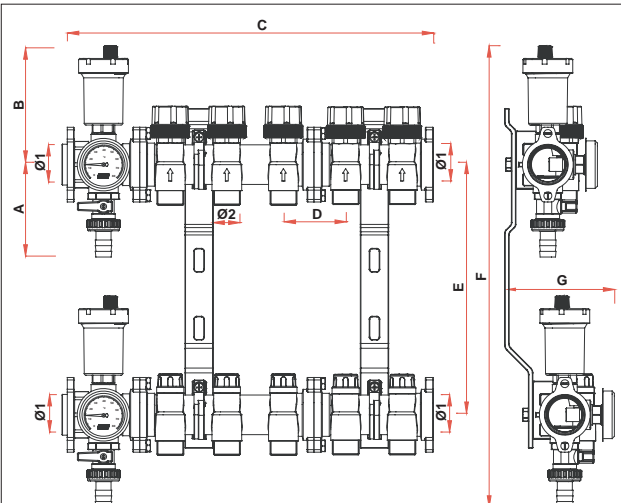

CODE	OUT.	Ø1	A	B	C	D	E	F	G	Ø2
3465-3471	2	G1	83	101	170	50	210-230	395-415	96	24x19-G3/4
3465-3471	3	G1	83	101	220	50	210-230	395-415	96	24x19-G3/4
3465-3471	4	G1	83	101	270	50	210-230	395-415	96	24x19-G3/4
3465-3471	5	G1	83	101	325	50	210-230	395-415	96	24x19-G3/4
3465-3471	6	G1	83	101	375	50	210-230	395-415	96	24x19-G3/4
3465-3471	7	G1	83	101	425	50	210-230	395-415	96	24x19-G3/4
3465-3471	8	G1	83	101	475	50	210-230	395-415	96	24x19-G3/4
3465-3471	9	G1	83	101	530	50	210-230	395-415	96	24x19-G3/4
3465-3471	10	G1	83	101	580	50	210-230	395-415	96	24x19-G3/4
3465-3471	11	G1	83	101	630	50	210-230	395-415	96	24x19-G3/4
3465-3471	12	G1	83	101	680	50	210-230	395-415	96	24x19-G3/4

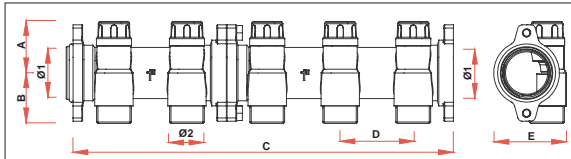

CODE	OUT.	Ø1	A	B	C	D	E	Ø2
3915-3918	2	G1	35	36	105	50	50	24x19-G3/4
3915-3918	3	G1	35	36	155	50	50	24x19-G3/4
3915-3918	4	G1	35	36	205	50	50	24x19-G3/4
3915-3918	5	G1	35	36	260	50	50	24x19-G3/4
3915-3918	6	G1	35	36	310	50	50	24x19-G3/4
3915-3918	7	G1	35	36	360	50	50	24x19-G3/4
3915-3918	8	G1	35	36	410	50	50	24x19-G3/4
3915-3918	9	G1	35	36	465	50	50	24x19-G3/4
3915-3918	10	G1	35	36	515	50	50	24x19-G3/4
3915-3918	11	G1	35	36	565	50	50	24x19-G3/4
3915-3918	12	G1	35	36	615	50	50	24x19-G3/4

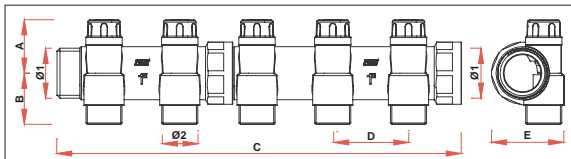

CODE	OUT.	Ø1	A	B	C	D	E	Ø2
3923-3921	2	G1	36	34	116	50	48	24x19-G1/2-G3/4
3923-3921	3	G1	36	34	166	50	48	24x19-G1/2-G3/4
3923-3921	4	G1	36	34	216	50	48	24x19-G1/2-G3/4
3923-3921	5	G1	36	34	268	50	48	24x19-G1/2-G3/4
3923-3921	6	G1	36	34	318	50	48	24x19-G1/2-G3/4
3923-3921	7	G1	36	34	368	50	48	24x19-G1/2-G3/4
3923-3921	8	G1	36	34	418	50	48	24x19-G1/2-G3/4
3923-3921	9	G1	36	34	470	50	48	24x19-G1/2-G3/4
3923-3921	10	G1	36	34	520	50	48	24x19-G1/2-G3/4
3923-3921	11	G1	36	34	570	50	48	24x19-G1/2-G3/4
3923-3921	12	G1	36	34	620	50	48	24x19-G1/2-G3/4
3923-3921	2	G1 1/4	41	38	116	50	58	24X19-G3/4
3923-3921	3	G1 1/4	41	38	166	50	58	24X19-G3/4
3923-3921	4	G1 1/4	41	38	218	50	58	24X19-G3/4
3923-3921	5	G1 1/4	41	38	268	50	58	24X19-G3/4
3923-3921	6	G1 1/4	41	38	318	50	58	24X19-G3/4
3923-3921	7	G1 1/4	41	38	368	50	58	24X19-G3/4
3923-3921	8	G1 1/4	41	38	418	50	58	24X19-G3/4
3923-3921	9	G1 1/4	41	38	470	50	58	24X19-G3/4
3923-3921	10	G1 1/4	41	38	520	50	58	24X19-G3/4
3923-3921	11	G1 1/4	41	38	570	50	58	24X19-G3/4
3923-3921	12	G1 1/4	41	38	620	50	58	24X19-G3/4

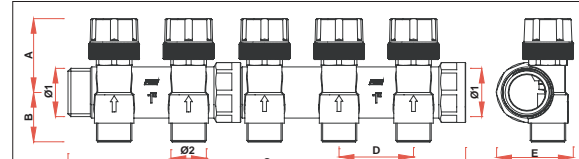

CODE	OUT.	Ø1	A	B	C	D	E	Ø2
3913-3911	2	G1	51	34	116	50	52	24x19-G1/2-G3/4
3913-3911	3	G1	51	34	166	50	52	24x19-G1/2-G3/4
3913-3911	4	G1	51	34	216	50	52	24x19-G1/2-G3/4
3913-3911	5	G1	51	34	268	50	52	24x19-G1/2-G3/4
3913-3911	6	G1	51	34	318	50	52	24x19-G1/2-G3/4
3913-3911	7	G1	51	34	368	50	52	24x19-G1/2-G3/4
3913-3911	8	G1	51	34	418	50	52	24x19-G1/2-G3/4
3913-3911	9	G1	51	34	470	50	52	24x19-G1/2-G3/4
3913-3911	10	G1	51	34	520	50	52	24x19-G1/2-G3/4
3913-3911	11	G1	51	34	570	50	52	24x19-G1/2-G3/4
3913-3911	12	G1	51	34	620	50	52	24x19-G1/2-G3/4
3913-3911	2	G1 1/4	56	38	116	50	62	24X19-G3/4
3913-3911	3	G1 1/4	56	38	166	50	62	24X19-G3/4
3913-3911	4	G1 1/4	56	38	218	50	62	24X19-G3/4
3913-3911	5	G1 1/4	56	38	268	50	62	24X19-G3/4
3913-3911	6	G1 1/4	56	38	318	50	62	24X19-G3/4
3913-3911	7	G1 1/4	56	38	368	50	62	24X19-G3/4
3913-3911	8	G1 1/4	56	38	418	50	62	24X19-G3/4
3913-3911	9	G1 1/4	56	38	470	50	62	24X19-G3/4
3913-3911	10	G1 1/4	56	38	520	50	62	24X19-G3/4
3913-3911	11	G1 1/4	56	38	570	50	62	24X19-G3/4
3913-3911	12	G1 1/4	56	38	620	50	62	24X19-G3/4

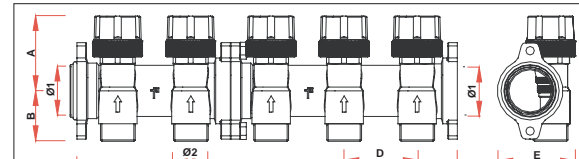

CODE	OUT.	Ø1	A	B	C	D	E	Ø2
3914-3917	2	G1	35	52	105	50	54	24x19-G3/4
3914-3917	3	G1	35	52	155	50	54	24x19-G3/4
3914-3917	4	G1	35	52	205	50	54	24x19-G3/4
3914-3917	5	G1	35	52	260	50	54	24x19-G3/4
3914-3917	6	G1	35	52	310	50	54	24x19-G3/4
3914-3917	7	G1	35	52	360	50	54	24x19-G3/4
3914-3917	8	G1	35	52	410	50	54	24x19-G3/4
3914-3917	9	G1	35	52	465	50	54	24x19-G3/4
3914-3917	10	G1	35	52	515	50	54	24x19-G3/4
3914-3917	11	G1	35	52	565	50	54	24x19-G3/4
3914-3917	12	G1	35	52	615	50	54	24x19-G3/4

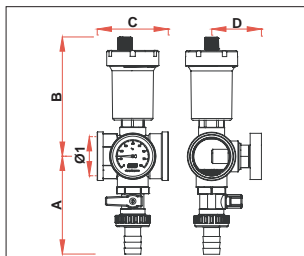

CODE	A	B	C	D	Ø1
3438 1	82	103	60	43	G1
3438 114	89	107	65	50	G1 1/4
3438 112	94	112	72	52	G1 1/2

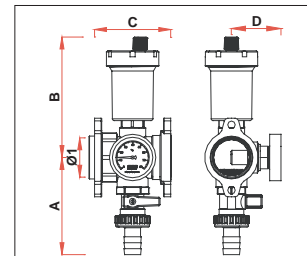

CODE	Ø1	A	B	C	D
3445 1	G1	82	105	64	43