

COMPONENTS FOR SOLAR HEATING SYSTEMS

1. SOLARFAR THERMOSTATIC MIXER



Art. 3953

SOLARFAR - Chrome-plated thermostatic mixer for solar systems.

- Setting range: 25÷65°C
- Connections: 1/2"-3/4"-1" female
- Max. input temperature: 120°C



Art. 3954

SOLARFAR - Chrome-plated thermostatic mixer for solar systems.

- Flat-faced connection preset for unions
- Setting range: 25÷65°C
- Connections: 3/4"-1" male
- Max. input temperature: 120°C



Art. 3955

SOLARFAR - Chrome-plated thermostatic mixer for solar systems.

- Flat-faced connection preset for unions
- Setting range: 25÷65°C
- Connections: 1/2"-3/4" male
- Max. input temperature: 120°C

1.1 DESCRIPTION

The SOLARFAR mixers are designed to constantly maintain the temperature of the mixed water distributed to system outlets at the set value, despite variations in fluid temperature, pressure and flow conditions. Moreover it permits to avoid

accidental use of very hot water, that might cause scalding, thanks to an anti-scald device, which stops the hot flow in the absence of cold water.

1.2 FUNCTIONING

The mixer is equipped with a thermo-sensitive element, which detects the temperature of the mixed fluid. The sensor is directly immersed into the mixed water, permitting maximum accuracy and speed of response. The sensor continuously monitors changes in water temperature and adjusts cold and hot water

inlets to achieve the correct proportions of each and thus the set temperature.

N.B. in order to increase mixer accuracy it is essential to balance pressure between cold and hot water inlets.

1.3 CALIBRATION

Valve calibration, i.e. setting the temperature of the water exiting the mixing valve, is carried out manually by turning the graduated handle.

The graduations are shown as follows:

HANDLE POSITION	MIN	1	2	3	4	5	MAX
°C TEMPERATURE	25	35	45	50	55	60	65

1.4 INSTALLATION

- Before installation carefully clean the pipes to remove sand, metal shavings and rust flakes in order to guard against any blockage of the shutter.
- Installation of strainers is recommended to keep the system free of impurities, which could impair mixer operation.
- In system with thermostatic mixers it is necessary to install non-return valves to avoid undesirable back flow. Moreover, if the hydraulic network has a pressure higher than 5 bar, a

pressure reducing valve must be installed.

- The mixer can be installed at any position.
- During installation it is important to match the connections as shown on mixer body: HOT for hot water supply; COLD for cold water supply and MIX for mixed water outlet.

1.5 TECHNICAL AND FLUID DYNAMIC FEATURES

Technical features

Max. working pressure:	10 bar
Recommended pressure:	1÷5 bar
Max. hot water temperature:	120 °C
Setting range:	25°C - 65°C
Body:	CW617N brass
Connections:	1/2" - 3/4" - 1"

Fluid dynamic features

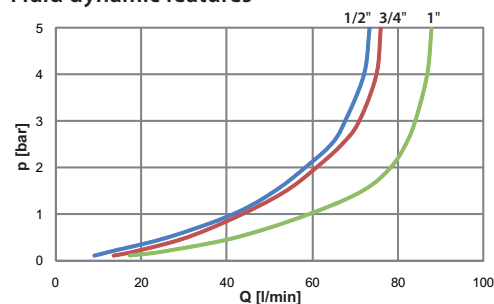

1/2" Kv = 2,2 m³/h
3/4" Kv = 2,6 m³/h
1" Kv = 3,6 m³/h

2. SOLARFAR SAFETY VALVE



Chrome-plated safety valve for solar systems.

- Inlet: 1/2" female
- Outlet: 3/4" female
- Max. temperature: 160°C

Available calibrations:
2.5 - 3 - 3.5 - 4 - 5 - 6 - 7 - 8 - 10 bar

Technical Features

PED class:	IV
Body and cap:	UNI EN 12165 CW617N brass
Stem:	UNI EN 12164 CW614N brass
Gaskets and membrane:	EPDM (for hot temperature)
Spring:	UNI EN 10270-1 steel
Handle:	Nylon®
Nominal pressure:	PN10
Temperature range:	-30÷160°C
Opening overpressure:	10%
Closing tolerance:	20%

2.1 DESCRIPTION

In order to protect solar panels, a safety valve and an expansion tank should be installed in the circuit. The valve can also be used for protection of any solar tank. The safety valve limits hot water pressure in such a way as not to exceed the calibrated set limit. Once this value is reached the valve will discharge a sufficient quantity of water to ensure that pressure is within the limits for correct operation of the system.

In order to achieve proper valve calibration, it is important that calibration pressure plus permitted overpressure does not exceed max. working pressure. All safety valves are calibrated

in our laboratories and it is not possible to change the value without tampering with them. In the event of a pipeline section being installed on the outlet, the diameter of the discharge pipeline must not be less than that of the outlet fitting and must not prevent the proper operation of the valves. The outlet must not be located near the safety valve and be both easily visible and accessible. To avoid any possibility of impurities being deposited on the shutter, the safety valve must not be installed with the leaflet downward.

Installation in solar system-overview

Safety valves must be installed close to the boiler tank and any shut-off valve cannot absolutely be installed between the safety valve and the boiler tank.

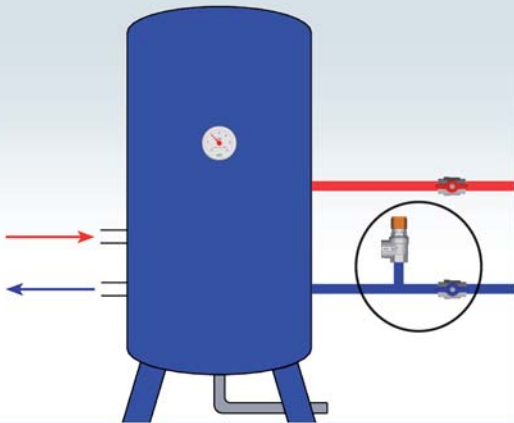

To protect the expansion tank and the system it is advisable to install the safety valve before the latter one.

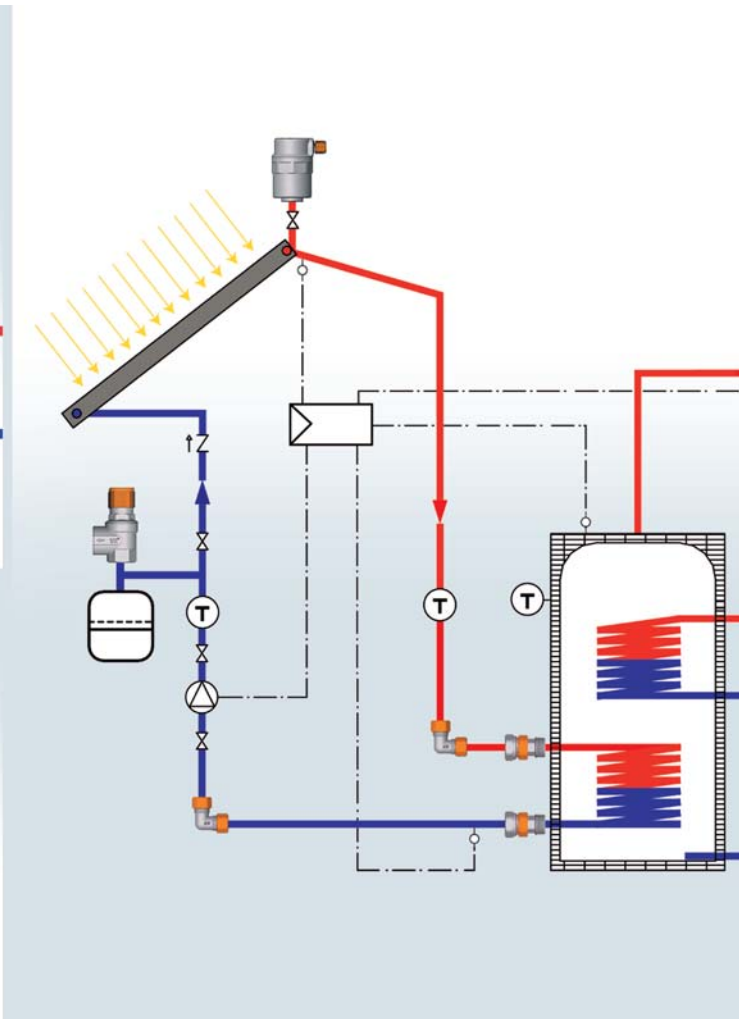
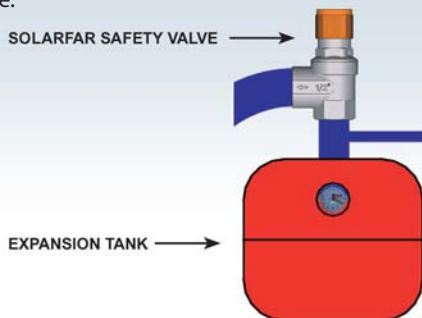

3. SOLARFAR FITTINGS

3.1 DESCRIPTION

SOLARFAR fittings permit connection of copper and steel pipes in solar systems and have a max. working temperature of 160°C.



Art. 5870
Male nipple complete with sealing kit



Art. 5872
Female nipple complete with sealing kit



Art. 5874
Double nipple complete with sealing kit



Art. 5876
Male elbow complete with sealing kit



Art. 5878
Female elbow complete with sealing kit



Art. 5880
Double elbow complete with sealing kit

3.2 SEALING COMPRESSION KIT INSTALLATION

- Insert the nut on pipe
- Insert the brass ring on pipe
- Insert the rubber single-taper on pipe
- Place the sealing kit with pipe into the conical seat of fitting
- Tighten the nut

Take care to insert the pipe in straight line, in order to ensure the sealing.

N.B. sealing on copper pipes is guaranteed by pipe thickness equal or higher than 1 mm. For inferior thickness (0.5 ± 0.7 mm) it is necessary to insert a metal ring inside the pipe. To avoid unthreading of pipe, tighten the nut properly. The minimum torque is: 40 Nm.

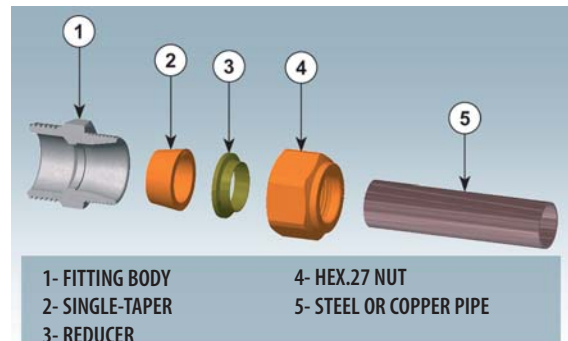

3.3 3-PIECE CONNECTION

SOLARFAR fittings permit connection of threaded pipes in solar systems and have a max. working temperature of 160°C. The sealing o-ring is made of heat-resistant material.



Art. 5152
3-piece connection for solar systems



3.4 TECHNICAL FEATURES

Working temperature:	160°C
Max. working pressure:	16 bar
Reducer:	CW614N brass
Single-taper:	FKM
Nuts:	CW617N brass
Fittings body:	CW617N brass
Sealing o-ring:	FKM

4. SOLARFAR AIR VENT VALVES
4.1 DESCRIPTION

The air vent valve art. 2042 has to be installed on solar heating systems to automatically vent any air in the circuit, thus ensuring a better heat transfer. Air discharge from the system avoids noise problems arising from imperfect fluid circulation. The valve must be installed at the highest point of the systems and in a vertical position in order to guarantee perfect operation.

Normally the cap has to be slightly loose to allow air to escape from the valve through a notch on the male thread. The plastic cap is provided with a sealing seat and can be closed if necessary.

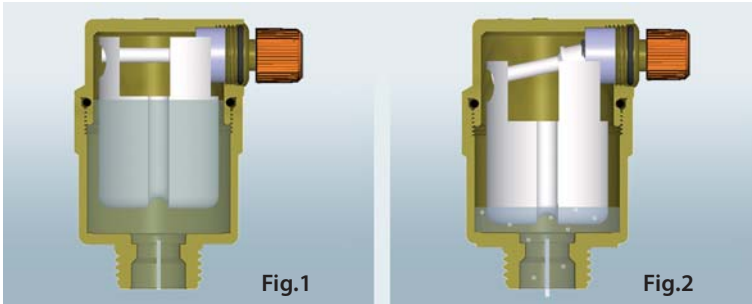
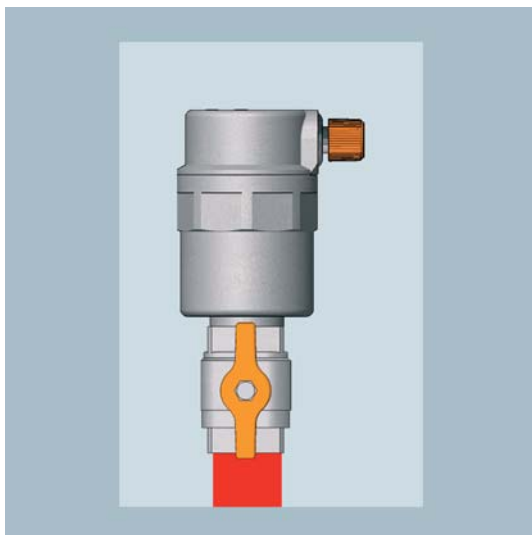

Fig.1 - If there is no air in the circuit, water inside the air vent valve keeps the float in such a position as to close the shutter.

Fig.2 - The air in the circuit reduces the water level in the air vent valve, thus lowering the float and opening the air discharge.

If debris in the system interferes with the normal working of the valve, it is possible to unscrew and remove the cover and float. On the stem holding the float is a rubber disk, which operates as a shutter when the float lifts the stem. It is essential to check for the presence of any debris which

may prevent the shutter reaching the end of its stroke. A plastic flow separator placed inside the 3/8" or 1/2" connection forces the air bubbles upwards and generates micro-currents in the fluid which ease any bubbles towards the higher side of the valve.

Example of SOLARFAR air vent valve installation in a solar system with forced circulation

It is necessary to install a shut-off valve to exclude the air vent valve, once the system filling is completed. This is essential as the antifreeze fluid could be vented in gaseous state, hindering the regular systems functioning.

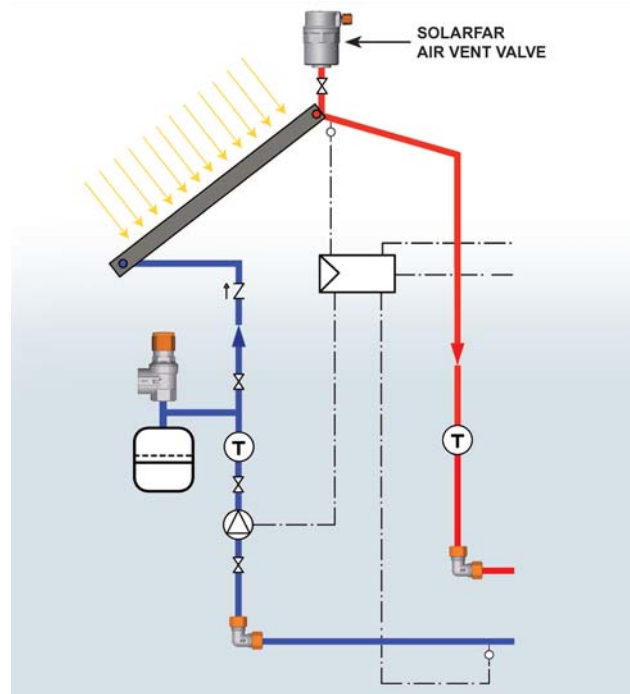
4.2 TECHNICAL FEATURES

Nominal pressure:	10bar
Max. fluid temperature:	160°C
Max. differential pressure:	4 bar
Compatible fluids:	water, water with glycol
Available connections:	3/8" e 1/2"

5. SOLARFAR DIVERTING ZONE VALVE

5.1 DESCRIPTION

The 3-way zone valve with L passage is a diverter valve with inlet from below and fluid delivery towards right or left according to the actuator position (Fig.1), or conversely inlet from right or left towards the centre (Fig.2).



Art. 300729

Before installing the actuator, it is essential to check that the flow aperture in the ball of the valve is orientated in the desired direction. The valve can be operated by means of a screwdriver. The silk-screen printed regulating stem shows the ball position.

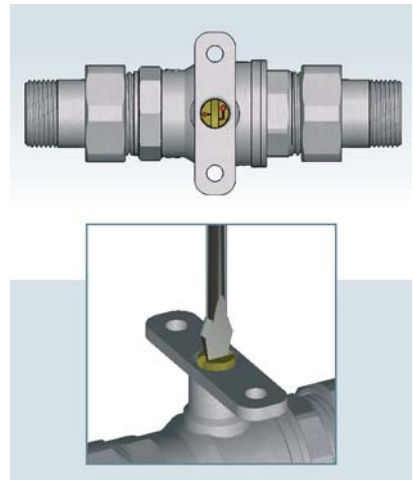
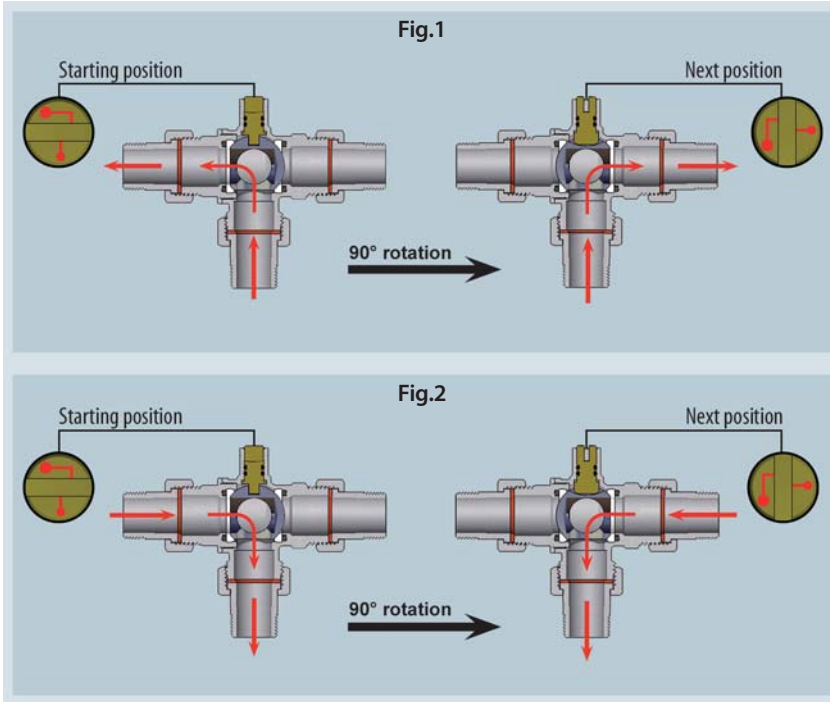

5.2 SOLAR SYSTEM WITH NORMAL CIRCULATION – INSTALLATION OVERVIEW

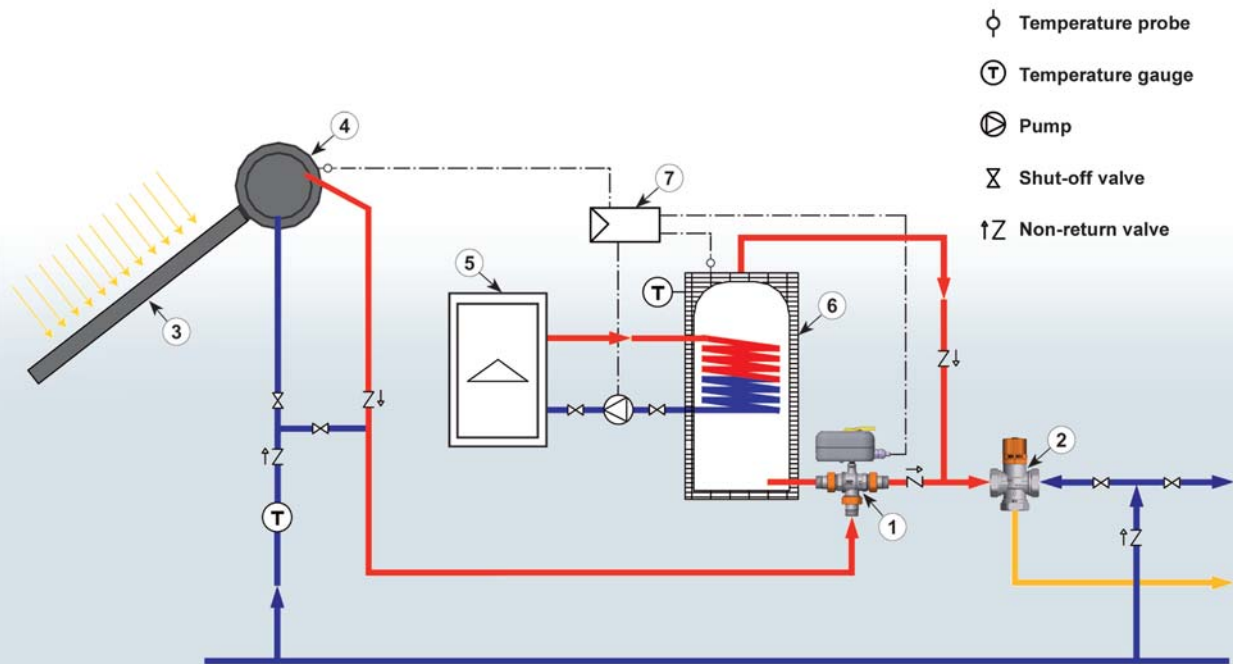

- | | |
|--------------------------------|-----------------|
| 1- SOLARFAR DIVERTER VALVE | 4- Panel tank |
| 2- SOLARFAR THERMOSTATIC MIXER | 5- Boiler |
| 3- Thermal solar panel | 6- Boiler tank |
| | 7- Control unit |

5.3 SOLAR SYSTEM WITH FORCED CIRCULATION – INSTALLATION OVERVIEW

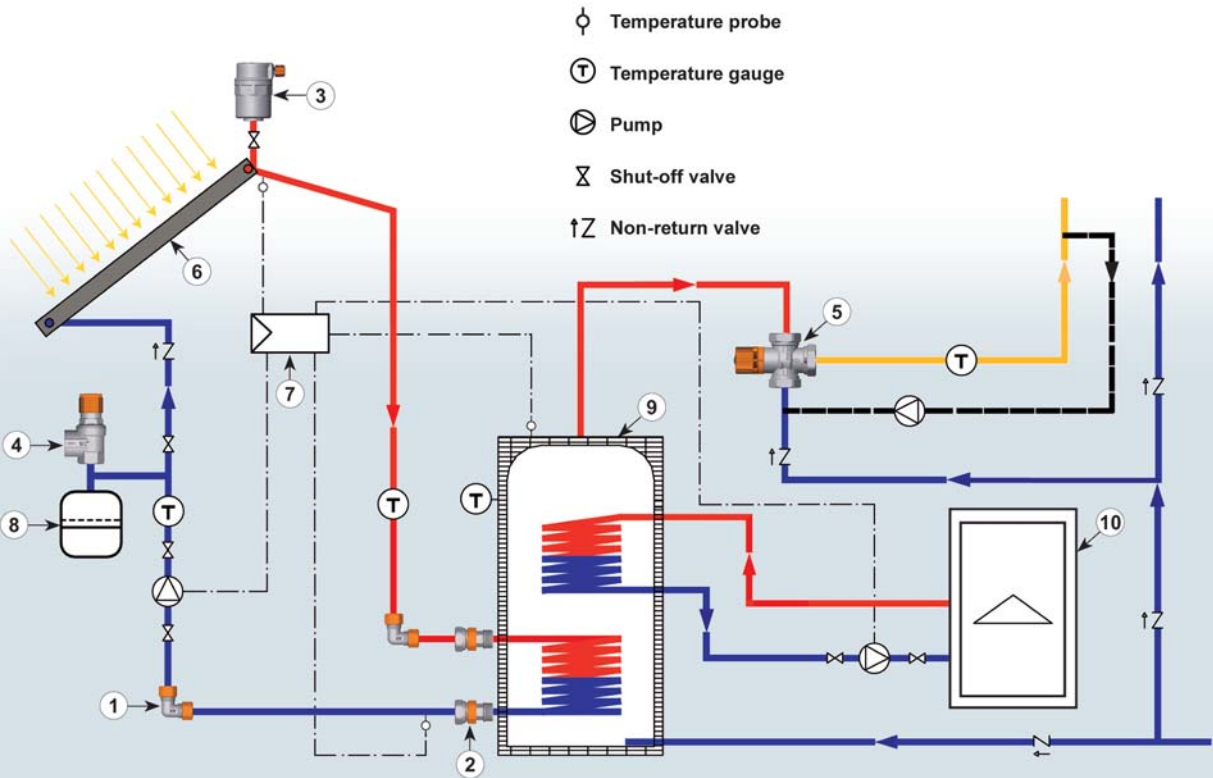

- 1- SOLARFAR ELBOW
- 2- SOLARFAR 3-PIECE CONNECTION
- 3- SOLARFAR AIR VENT VALVE
- 4- SOLARFAR SAFETY VALVE
- 5- SOLARFAR THERMOSTATIC MIXER
- 6- Thermal solar panel
- 7- Control unit
- 8- Expansion tank
- 9- Tank
- 10- Boiler

6. DIMENSIONAL FEATURES

